



213/215/217
Patient Simulators

Operating and Service Manual





213/215/217

Patient Simulators

Operating and Service Manual



Copyright: Dynatech Nevada, Inc. agrees to a limited copyright release that allows you to reproduce manuals and other printed materials for use in service training programs and other technical publications. If you would like other reproductions or distributions, submit a written request to Dynatech Nevada Inc.

Warranty and Product Support: This instrument was thoroughly tested and found to meet our manufacturing specifications when it was shipped from the factory. Calibration measurements are traceable to the National Institute of Standards and Technology (NIST).

| |
|--|
| <p>New Instrument Warranty 1 year on parts and labor Physical damage is not covered</p> <p>Repair Instrument Warranty 1 year on calibration, labor, and parts replacement Physical damage is not covered</p> |
|--|

Dynatech Nevada Inc. warrants that all products are to be free from defects in parts and labor as described in the warranty policy unless a different period is specified. If you discover a defect, Dynatech Nevada will either modify the product to correct the defect, replace the product with new or factory reconditioned products, or refund the amount paid for the defective product. The standard terms and conditions of sale are printed on the reverse side of the Dynatech Nevada invoice. You may obtain additional copies of the warranty and conditions of sale from Dynatech Nevada.

If you return an instrument to Dynatech Nevada Inc., we recommend United Parcel Service, Federal Express, or Air Parcel Post. You must receive prior authorization from Dynatech Nevada Inc. for C.O.D. shipments, otherwise you will pay transportation charges.

Intended Use Disclaimer: The 213/215/217A is intended to be used as a simulation device only. Recommended applications include routine preventive maintenance inspections, sales demonstrations, or training. The 213/215/217A is not to be used as the primary calibration standard or the certification test instrument for medical devices.

©Copyright Fluke Corporation

Fluke Biomedical

6920 Seaway Blvd.

Everett, WA 98203

Sales & Customer Service

775-883-3400 • 800-648-7952

<http://www.flukebiomedical.com> • sales@flukebiomedical.com

Service and Repair

Please call for RMA number before shipping

1420 75th Street SW

Everett, WA 98203

888-99FLUKE (888-993-5853) • 425-446-5560

Patient Simulators Models 213A, 215A and 217A.

Your Dynatech Nevada Patient Simulator has the latest level 2.0 software. New features such as ST segment elevation/depression, IABP arterial BP augmentation, defibrillation training and pediatric ECG simulation have been added. Standard features such as ECG rate, static BP pressure, and artifact now have a wider range of selections. Patient simulators with earlier software versions can be factory updated.

Patient Simulator Controller/Cardiac Output Simulator, Model 21A:

Dynatech Nevada has an excellent accessory for your new patient simulator! The Model 21A simplifies the use of the patient simulator and adds direct waveform access, user programmable waveform trending/sequencing and cardiac output simulation.

Contact Dynatech Nevada directly or the exclusive sales representative in your area for more information.

New Level 2.0 Software Update Features:

ECG (All Models)

Normal Sinus

Rates: 30, 60, 80, 120, 160, 200, 240, 300 BPM

ST Segments: Normal, Elevated or Depressed.

ST Segment Steps: 0.05, 0.1, 0.15, 0.2, 0.5, 0.8 millivolts. (Lead II)

Axis Deviation: Normal, Horizontal, and Vertical.

Pediatric ECG: 40 mSec R wave width.

Blood Pressure

BP Channel One (Models 215 and 217 only)

Static Levels: 0, 20, 40, 80, 100, 200, 250, 300 mmHg

All dynamic blood pressure waveforms are reduced 25% in amplitude during pediatric ECG simulation.

Intra-Aortic Balloon Pump Assist

(Models 215 and 217 only)

The arterial blood pressure waveform in BP channel one is augmented to simulate the patient's response to an intra-aortic balloon pump device. The IABP inflation and deflation timing sync pulse is input to the patient simulator and the arterial blood pressure waveform is augmented during that specific time period. Improper settings on the IABP (i.e.: early deflate or late deflate), will cause a physiologically accurate response on the arterial blood pressure waveform.

ECG Rates: 30, 60, 80, and 120 BPM.

Arrhythmias: Atrial Fibrillation, PVC/6min, Paced/Continuous, Paced/Demand, Run of 5 PVCs, and Run of 11 PVCs.

Artifact

ECG (All Models)

ECG: 50 Hz, 60 Hz, Muscle or baseline wander artifact can be added to any ECG selection at three different levels. Artifact can be added to all or any of the following single signal leads: RA, LA, LL, or V1/C.

Blood Pressure/Respiration (Models 215 and 217 only)

Two selectable pressure values in phase with respiratory activity are mixed with all dynamic blood pressure selections.

Arterial and LV waveforms are amplitude modulated and all right heart pressures including PA wedge have the respiratory offset signal summed in the output.

Defibrillator Training

(All Models)

Scenarios are programmed which are encountered by medical personnel during cardiac emergencies and elective cardioversion procedures. With the simulator connected to 1000:1 oscilloscope output of a defibrillator analyzer, cardiac rhythms such as ventricular fibrillation and atrial fibrillation will be converted to normal sinus rhythm.

Emergency 1: Normal Sinus Rhythm (NSR) with PVC activity terminates into ventricular fibrillation (V-FIB).*

Emergency 2: NSR with a run of 5 PVCs terminating into V-FIB.*

*If the defibrillator pulse is sensed at the simulator sync input, the ECG output will initially convert to a slow nodal rhythm and then remain in NSR.

Cardioversion: Atrial fibrillation is output until the defibrillator is discharged. If properly synchronized (within 120 milliseconds of the R wave peak), conversion to NSR will occur. If it is not synchronized, the ECG output will degrade to V-FIB. Emergency defibrillation must be accomplished to achieve conversion to NSR.

If a defibrillator is not available, waveforms can be advanced from either the simulator front panel pushbuttons or the patient simulator controller, Model 21A.

Contents

| | |
|---|-----|
| WARRANTY | III |
| CERTIFICATION | III |
| COPYRIGHT RELEASE | III |
| DAMAGE | IV |
| CONCEALED DAMAGE | IV |
| SHORTAGE | IV |
| CLAIMS | IV |
| LOSS | V |
| AIR FREIGHT | V |
| DAMAGE CLAIMS | V |
| LOSS CLAIMS | V |
| CLAIM FOR DAMAGE TO UPS SHIPMENTS | VI |
| UNPACKING AND INCOMING INSPECTION | VI |
| CLAIMS | VI |
| WARRANTY REPAIR | VI |
| REPACKAGING FOR SHIPMENT | VII |

| | |
|--|----------|
| CHAPTER 1 - SPECIFICATIONS | I |
| ECG | 3 |
| BLOOD PRESSURE (MODELS 215 AND 217 ONLY) | 4 |
| RESPIRATION (MODELS 215 AND 217 ONLY) | 5 |
| ARTIFACT | 6 |
| DEFIBRILLATOR | 6 |
| INTRA-AORTIC BALLOON PUMP (IABP) (MODELS 215 AND 217 ONLY) | 7 |

| | |
|---|----------|
| CHAPTER 2 - OPERATING INSTRUCTIONS | 9 |
| POWER | 11 |
| BATTERY REPLACEMENT | 11 |
| FRONT PANEL OPERATION | 11 |
| Display | 11 |
| Menu Organization | 11 |
| Main Key | 11 |
| Execute Key | 12 |
| Sub Key | 12 |
| Cursor Key | 12 |
| TOP PANEL OPERATION | 12 |
| Blood Pressure | 12 |
| Temperature | 12 |
| Respiration | 13 |

Contents

| | |
|-----------------------------|----|
| 1 Volt ECG | 13 |
| Remote | 13 |
| RS-232 | 13 |
| REAR PANEL CONNECTORS | 13 |
| ecg | 13 |
| Batt Elim | 13 |
| Defib Sync | 14 |
| MENUS | 14 |
| User Menu | 14 |
| ecg | 14 |
| Blood Pressure | 19 |
| Respiration | 21 |
| Artifact | 21 |
| Defibrillator | 22 |
| Utility | 24 |
| POWER UP CONDITIONS | 24 |
| USER MENU | 25 |
| RS-232 | 26 |

CHAPTER 3 - CALIBRATION PROCEDURE 37

| | |
|---|----|
| CAPACITIVELY COUPLED REAR PANEL CALIBRATION PROCEDURE | 39 |
| INTRODUCTION | 40 |
| FRONT PANEL CALIBRATION | 40 |
| View Angle | 42 |
| Model Number | 43 |
| BP Offset and Linearity (See Figure 3.2) | 43 |
| ecg Amplitude | 43 |
| Respiration | 43 |
| Blood Pressures | 44 |
| Exit | 44 |
| RS-232 CALIBRATION | 44 |

CHAPTER 4 - CIRCUIT DESCRIPTION 49

| | |
|--|----|
| BLOCK DIAGRAM DESCRIPTION (FIGURE 4.1) | 51 |
| SCHEMATIC 1 | 53 |
| SCHEMATIC 2 | 53 |
| SCHEMATIC 3 | 54 |
| SCHEMATIC 4 | 55 |
| SCHEMATIC 5 | 55 |

CHAPTER 5 - PARTS LIST 57

**CHAPTER 6 - COMPONENT LOCATOR
AND SCHEMATICS 73**

CHAPTER 7 - ADDENDA 87



217A Patient Simulator

CHAPTER I
SPECIFICATIONS

ECG

GENERAL:

Lead Configuration: Full 12 Lead capability with independent outputs for each signal lead referenced to RL.

Output impedance: 1000 ohms from each lead to RL.

Amplitudes specified are for the peak R wave in lead II in a normal axis heart. Other leads are proportional as they would be in a human body.

NORMAL SINUS:

RATES: 30, 60, 80, 120, 160, 200, 240, and 300 BPM (Beats Per Minute).

AMPLITUDES: 0.5, 1.0, 1.5 and 2.0 mV.

AXIS DEVIATION: Normal, Horizontal, and Vertical.

ST SEGMENT VARIATION: Positive and Negative deviations of .05, .1, .15, .2, .5, and .8 times the R wave amplitude.

PEDIATRIC BEATS: A narrower heartbeat and lower blood pressures (see below).

ECG PERFORMANCE:

(amplitudes are for lead II and V1-V6, leads I and III are 1/2 amplitude)

SQUARE: 2 Hz at 1mV.
Amplitude accuracy is +/- 5% on lead II.

PULSE: 4 seconds at 1 mV.

SINE: 10, 40, 50, 60 and 100 Hz at 1 mV.

TRIANGLE: 2 Hz at 3mV.

ARRHYTHMIAS:

45 SELECTIONS of the following types:

- Supraventricular(9)
- Premature(9)
- Ventricular(15)
- Conduction(6)
- Pacemaker(6)

BASE NORMAL BEAT: 80 BPM at 1 mV amplitude. This is the type of normal beat used within arrhythmias.

PACEMAKER SPIKE:

Duration: .15 mSec.

Amplitude: 4.8 mV on lead II, 2.4 mV on leads I and III and V1-V6.

OUTPUT CONNECTORS:

LOW LEVEL OUTPUTS: 10 color coded special purpose binding posts. Mates with snap electrodes and 3.2 and 4.0 mm pins (IEC color codes available).

1 VOLT OUTPUT: 1/4 inch standard phone jack with lead II waveform at 1 V per mV of the low level lead II signal.

BLOOD PRESSURE (MODELS 215 AND 217 ONLY)

INPUT/OUTPUT IMPEDANCE: 300 ohms.

EXCITER INPUT VOLTAGE RANGE: 2 to 10 V.

EXCITER INPUT FREQUENCY RANGE: DC to 4000 Hz.

OUTPUT SENSITIVITY: 5 or 40 uV/V/mmHg.

OUTPUT RANGE: 0-300 mmHg on BP-1 and 0-30 mmHg on BP-2 and BP-3.

ACCURACY: 1% of range + 1% of setting + 1 count

RATES: All dynamic pressures are synchronized with all normal sinus rates, and physiologically track all arrhythmias. Systolic/Diastolic values are for rates of 80 BPM or less. At higher rates, the Systolic pressure stays the same and the Diastolic increases as the rate increases.

BLOOD PRESSURE CHANNEL 1 SELECTIONS:

ATM: 0 mmHg
ARTERIAL: 120/80 mmHg
LEFT VENTRICLE: 120/0 mmHg
RIGHT VENTRICLE: 25/0 mmHg
PULMONARY ARTERY: 25/10 mmHg
PULMONARY WEDGE: 10/2 mmHg
STATIC LEVELS: 0, 20, 40, 80, 100, 200, 250 and 300 mmHg

BLOOD PRESSURE CHANNEL 2 SELECTIONS:

ATM: 0 mmHg
CENTRAL VENOUS: 15/10 mmHg
RIGHT VENTRICLE: 25/0 mmHg
PULMONARY ARTERY: 25/10 mmHg
PULMONARY WEDGE: 10/2 mmHg
STATIC LEVELS: 0, 5, 10, 20 and 30 mmHg

BLOOD PRESSURE CHANNEL 3 SELECTIONS: (model 217 only)

SWAN-GANZ procedure: ATM-CVP-RV-PA-WEDGE
Manually sequenced.

PEDIATRIC SELECTION:

All blood pressure amplitudes are reduced to 75% of normal levels.

RESPIRATION (MODELS 215 AND 217 ONLY)

OUTPUT CONFIGURATION

Lead I, II or RL-LL.

BASELINE IMPEDANCE: 500 or 1000 ohms.

NORMAL PHYSIOLOGICAL SIMULATION

RATES: 15, 20, 30, 40, 60, and 120 BPM.

DELTA IMPEDANCE: 0, 0.1, 0.2, 0.5, 1.0 or 3.0 ohms.

APNEA: Off, Momentary, Continuous,
12 Sec and 32 Sec.

VENTILATOR SIMULATION

RATE: 40 BPM.

DELTA IMPEDANCE: 3.0 Ohms.

ARTIFACT

ECG:

50 Hz, 60 Hz, Muscle artifact, or baseline wander can be added to any ecg waveform. Selectable at x.5, x1, or x2 of a typical amplitude which is about 1/2 the R wave.

BLOOD PRESSURE:

Respiration artifact can be injected into any pressure waveform. Arterial and Left Ventricle waveforms are modulated by the selected respiration rate. Modulation on Arterial is 131/87 to 109/73. Modulation on Left Ventricle is 131/0 to 109/0. All other pressure waveforms have the respiration added to them with a value from 0 to 24 mmHg. The amount of artifact can be x.5 or x1 of the amount specified above.

DEFIBRILLATOR

Three interactive arrhythmias are included in which the patient goes into fibrillation and then may be defibrillated back to normal. The defibrillation may be from a pulse into the DEFIB SYNC input or by a menu selection. In the Cardioversion sequence, the timing of the defib pulse is measured in relation to the R wave, which determines whether defibrillation is successful.

DEFIB SYNC INPUT:

Triggered by a positive voltage greater than .4 Volts into an impedance of 10 kohms (+/-35 V max). Connector is a 1/8 inch miniature phone jack.

INTRA-AORTIC BALLOON PUMP (IABP) (models 215 and 217 only)

On the BP-1 channel, simulates the effect on arterial blood pressure of an assist from an intra-aortic balloon pump. Uses the DEFIB SYNC input to receive a signal from the balloon pump. When the pump goes on, the resultant effect is added to the arterial waveform. The effects of early, normal, and late inflation and deflation of the pump are simulated.

A high signal on the DEFIB SYNC indicates that the pump is on, and a low indicates the pump is off.

TEMPERATURE (models 215 and 217 only)

CHANNEL ONE: Fixed at 37 deg. C / 98.6 deg. F.

CHANNEL TWO: Selectable at

30 deg. C / 98.6 deg. F.

37 deg. C / 98.6 deg. F.

40 deg. C / 104 deg. F.

PROBE COMPATABILITY: 400 and 700 series YSI types.

ACCURACY: +/- 0.25 deg. C.

RS-232 INTERFACE

All functions may be controlled remotely. Baud rate is selectable at 300, 600, 1200 and 2400. Echo can be set on or off.

POWER

Nine volt alkaline battery (Duracell MN1604 or equivalent) provides 20 to 25 hours operation. Battery eliminator for line operation (Standard is for 115 VAC, European 230 VAC version available).

Note: Do not use mercury, air, or carbon-zinc batteries.

PHYSICAL CHARACTERISTICS

CASE CONSTRUCTION: High impact polystyrene

WEIGHT: 2 lb (.9 Kg)

SIZE: 7.5 x 5.4 x 1.8 inches (190 x 138 x 44 mm)

STANDARD ACCESSORIES

BATTERY ELIMINATOR

SOFT VINYL CARRYING CASE

INSTRUCTION MANUAL

OPTIONAL ACCESSORIES

BP CABLE unterminated
BP CABLE prewired for selected patient monitors
TEMPERATURE CABLE for 400 YSI only
TEMPERATURE CABLE for 400/700 YSI
HAND HELD REMOTE CONTROLLER
RS-232 CABLE

CHAPTER 2

OPERATING INSTRUCTIONS

POWER

The power switch is located on the top panel. To increase battery life, turn the instrument off when not in use or use the battery eliminator.

BATTERY REPLACEMENT

The battery compartment is accessible from the bottom of the unit. Replace with a 9 Volt alkaline battery (Duracell MN1604 or equivalent).

Note: Do not use mercury, air, or carbon-zinc batteries.

FRONT PANEL OPERATION**Display**

The display on the patient simulator provides information necessary for setting output levels and waveform types.

Menu Organization

The menus are arranged in three levels. Each MAIN MENU selection has a set of SUB MENUS and each SUB MENU selection has a list of EXECUTE MENUS. The main menu selections are in capital letters. In the sub menus only the first letter of each word is capitalized. Execute menus are all lower case letters. Execute menus also have a flashing cursor. The menus are listed in a chart below.

Main Key

The main key shifts the display upward through the menu levels. Depressing the main key when in an execute menu will shift the display to the appropriate sub menu. Depressing the main key when in a sub menu will shift the display to the associated main menu. Depressing the main key when in a main menu shifts to the next main menu selection. If the key is held in a key repeat function starts after about 1 second. The repeat function works for all keys.

Execute Key

The execute key shifts the display downward through the menu levels. Depressing the execute key when in a main menu will shift the display to the appropriate sub menu. Depressing the execute key when in a sub menu will shift the display to the associated execute menu. Depressing the execute key when an execute menu is displayed sets the appropriate output to that selection (ie. ECG, BP, RESPIRATION). When an execute menu selection is executed, the display will momentarily flash.

Sub Key

The sub key scrolls through either sub or execute menus depending on which menu has been selected.

Cursor Key

Execute menus have 1 or more cursor positions. The cursor will be seen flashing below a specific selection. The cursor can be moved to the desired selection with the cursor key. If the last character displayed is a ">", there are more cursor positions than can be displayed. The cursor key will automatically scroll to the next set, then back to the first set.

TOP PANEL OPERATION

Blood Pressure

Cables to connect to the blood pressure connectors are available from Dynatech. For many monitors, the cables are available pre-wired. Unterminated cables are available for other monitors (see figure 2.1). The SENSITIVITY switch must be set to match the patient monitor's input sensitivity. The waveforms outputted are set by the front panel menus.

Temperature

Cables to connect to the temperature connectors are available from Dynatech. The type of cable used determines the type of probe simulated, either 400 or 700 series YSI probes. The TEMP switch selects the temperature for the selectable output. Temperature cannot be controlled either from the front panel or via RS-232.

Respiration

The respiration signal is contained within the ECG signals on the rear panel. The LEAD SELECT switch determines which lead it is on. This must be set to correspond to the type of patient monitor used. The BASELINE IMPEDANCE switch sets the impedance between any two limb leads to be 500 ohms or 1000 ohms.

1 Volt ECG

1/4 inch standard phone jack with lead II waveform at 1 V per mV of the low level lead II signal. For use with high level input monitors.

Remote

A hand held remote controller available from Dynatech plugs in here. The controller has four keys that duplicate the front panel keys on the end of a cable.

RS-232

This can be connected to a computer or a terminal or to the Model 21 Patient Simulator Controller to remotely program the simulator. See section on RS-232 operation for more information.

REAR PANEL CONNECTORS**ecg**

Ten special binding posts are compatible with disposable snaps and 3.2 or 4 mm electrodes. All leads have independently generated signals. Waveforms are selectable from the front panel.

Batt Elim

Jack for the battery eliminator supplied with unit. Use only eliminators supplied by Dynatech.

Defib Sync

Jack for input of a pulse to defibrillate patients for waveforms in the DEFIBRILLATOR main menu. Also used for the pump signal input for IABP waveforms.

MENUS

Below is a listing of the main menus (all capitals), the sub menus (first letters capitalized), and execute menus (all lower case) and descriptions of each and notes.

User Menu

The execute menus under this main menu are defined by the user so that selections commonly used are more readily accessible. See UTILITY menu for setting this up.

ecg

Normal Sinus

Menus for selecting all the variations of the normal heart beat.

bpm30 60 80 120> 160 200 240 300>
Rate in beats per minute.

ampl 0.5 1.0 > ampl 1.5 2.0 >
Amplitude in mV (lead II).

axis nrm hrz vrt
Normal, horizontal, or vertical, axis deviation.

st off pos neg
ST segment variation off, or positive or negative variation.

st .05 .10 .15 > st .20 .50 .80 >
Amount of ST segment variation, when on, as a fraction of the height of the R wave.

peds off on >
Pediatric waveform, a narrower ecg wave and also lowers blood pressure dynamic waveform amplitudes to 75% of normal.

Note: ST variation only works with a normal axis adult heart (not pediatric) at rates of 160 BPM or less. The pediatric waveform only has a normal axis.

Ecg Performance

A group of waveforms to test ecg monitors for performance, including amplitude accuracy, damping, linearity, and frequency response.

sq 2Hz @ 1mV

Square wave, 2 Hz, 1 mV.

pulse 4s 1mV

Pulse for 4 sec, 1 mV. One pulse is generated each time execute is pushed.

sine 10 40 50 > sine 60 100 >

Sine waves, 1 mV. Frequency in Hz.

tri 2Hz 3mV

Triangle wave, 2 Hz, 3 mV.

Sv Arrhythmias

Supraventricular arrhythmia group.

Note: When a normal sinus beat is included as part of an arrhythmia, it is 1 mV at 80 BPM on a normal axis. Unless otherwise stated, the PR interval is .16 sec. When an arrhythmia contains one or more abnormal beats within a series of normal beats, the abnormal beat is the second beat of the total series starting after one normal beat. Every time EXECUTE is pushed restarts the series. This feature may be used to "inject" an abnormal beat at will by restarting the series.

afib1

afib2

Atrial fibrillation coarse(1) and fine(2). Rapid irregular atrial signal with no real P waves. Irregular ventricular rate.

aflutter

Atrial flutter. Large P waves at 300 BPM. Ventricular response at 5:1 for 12 sec, 13:1 for 6 sec, 2:1 for 6 sec repeating.

sinus arr

Sinus arrhythmia. Normal beats but triggered at irregular rate, from 60 to 100 BPM.

mb 80

mb 120

Missed beat at 80 and 120 BPM. Normal rhythm but every tenth beat is missing.

pat

Paroxysmal Atrial Tachycardia. 160 BPM for 5 sec alternating with normal beats for 12 sec.

nodal

Nodal rhythm. Normal except P wave originates in A-V node. Short PR interval of .09 sec.

svt

Supraventricular Tachycardia. Sinus rhythm at 160 BPM.

Premature

A group with premature beats mixed in with normal beats.

pac

Premature atrial contraction. Normal rhythm except every tenth beat is premature by 25%.

pnc

Premature nodal contraction. Nodal rhythm except every tenth beat is premature by 25%.

pvc 1

pvc 1 early

pvc 1 r on t

pvc 2

pvc 2 early

pvc 2 r on t

Premature ventricular contractions. A PVC 1 is from a left ventricular focus and a PVC 2 is from a right focus. Standard PVC's are 20% premature. Early PVC's are 33% premature. R on T PVC's are 65% premature (.25 sec after the previous normal R wave peak). In these six PVC arrhythmias every tenth beat is a PVC.

Note: Unless otherwise specified, PVC's have standard timing and are from a left focus (PVC 1).

multi-focal

Multi-focal PVC's. Alternating left and right focus PVC's spread among normal beats at 5 per minute.

Vent Rhythms 1

A group with various combinations of PVC's and normal beats.

pvcs 6/min

pvcs 12/min

pvcs 24/min

PVC's at the specified rate spread among normal beats.

freq mf 20/m

Frequent multi-focal PVC's, 20 per minute. Alternating left and right PVC's spread among normal beats.

bigeminy

Normal beat followed by a PVC, repeated.

trigeminy

Two normal beats followed by a PVC, repeated.

pair pvc

Two PVC's together in a series with 14 normal beats, repeated.

run 5 pvcs

Five PVC's together in a series with 8 normal beats, repeated.

run 11 pvcs

Ten left PVC's and one right PVC together in a series with 8 normal beats, repeated.

Vent Rhythms 2

A group with no normal beats.

ventricular

Ventricular rhythm. Similar to left focus PVC's at 120 BPM.

vtach

Ventricular tachycardia. Similar to left focus PVC's at 180 BPM.

vfib 1

vfib 2

Ventricular fibrillation. Irregular ventricular waveform, coarse(1) and fine(2). Coarse is twice the amplitude of fine.

emd

Electro-motive disassociation. Irregular weak signal.

asystole

No beats but vey small irregular signal remains.

Conduction

Various conduction defects.

1 deg. block

First degree A-V block. Normal beats except with long PR interval of .25 sec.

2 deg. block t 1

Second degree A-V block, type 1, Wenckebach. Increasing PR interval from .22 to .47 seconds followed by a P wave only with no QRS response, repeated. P waves at normal 80 BPM.

2 deg. block t 2

Second degree A-V block, type 2. Waveform similar to right bundle branch block except PR interval is .25 sec. 18 beats at 80 BPM

3 deg. block

Third degree A-V block. Normal waveforms except with a P wave rate of 80 BPM and a QRS rate of 30 BPM running independently of each other.

rbbb

lbbb

Right and left bundle branch block. Wide QRS complexes. An 80 BPM rate with a PR interval of .16 sec.

Paced Rhythms

Pacemaker waveforms. The wide QRST response to a pacer spike is similar to an LBBB because the pacemaker catheter tip is located in the right ventricle. The pacemaker rate is 75 BPM.

async 75 bpm

Asynchronous continuously paced.

demand 1

Mostly paced. A series of 40 paced beats and 20 normal beats. Pacer kicks in when normal beat is 20% late and kicks out when normal beat comes in time for 80 on BPM rate.

demand 2

Mostly paced. Same as demand 1 except 20 paced beats and 40 normal beats.

a-v seq

Atrial-Ventricular sequential. Dual pacer spikes. First triggers P wave, second triggers QRST, .15 sec apart.

non capture

Asynchronous paced except every tenth beat has no QRST response.

non function

Pacer spikes only. No QRST response.

Blood Pressure

Note: The following dynamic blood pressures are specified for their systolic and diastolic values for rates of 80 BPM and less. For higher rates the systolic stays the same but the diastolic pressure increases as the rate increases. All dynamic pressures are synchronized with all normal sinus rates, and physiologically track all arrhythmias.

Blood Pressure 1**atm**

Atmosphere 0 mmHg.

arterial

Arterial @ 120/80 mmHg.

left ventricle

Left ventricle @ 120/0 mmHg.

right vent

Right ventricle @ 25/0 mmHg.

pulm art

Pulmonary Artery @ 25/10 mmHg.

wedge

Wedge in the pulmonary artery @ 10/2 mmHg.

stat 0 20 40 80 > 100 200 250 300 >

Static levels, mmHg.

Blood Pressure 2

atm

Atmosphere 0 mmHg.

cvp

Central venous pressure @ 15/10 mmHg.

right vent

Right ventricle @ 25/0 mmHg.

pulm art

Pulmonary Artery @ 25/10 mmHg.

wedge

Wedge in the pulmonary artery @ 10/2 mmHg.

static 0 5 10 > static 20 30 >

Static levels, mmHg.

Blood Pressure 3

Note: The blood pressure 3 channel contains a Swan-Ganz procedure for inserting a catheter into a vein and through the heart into the pulmonary artery and inflating a wedging balloon, then deflating the balloon and removing the catheter. The menus describe the present position in the procedure and the options from that point, insertion to the next step, removal, or inflation or deflation of the balloon. The ecg waveform is automatically set to normal sinus 80 BPM whenever any BP3 menu is executed, but the ecg waveform may be set as desired after BP3 if set.

atm) ins>cvp Atmosphere 0 mmHg, insertion to central venous pressure.

cvp) ins>rv rem>

Central venous pressure @15/10 mmHg, insertion to right ventricle, or removal.

rv) ins>pa rem>

Right ventricle @ 25/0 mmHg, insertion to pulmonary artery, or removal.

pa) inf>w rem>

Pulmonary artery @ 25/10 mmHg, inflation to a wedge, or removal.

w) def>pa

Wedged pulmonary artery @ 10/2 mmHg, deflation back to normal pulmonary artery.

Note: If INS, INF, DEF, or REM commands are entered via the RS-232 port when it is impossible to perform them, a "?" is returned on the port. For example, INF cannot be executed unless the waveform is PA.

Respiration

Normal Resp

rate 15 20 30 > rate 40 60 120 >

Breathing rate in BPM.

ohms apn .1 .2 > ohms .5 1.0 3.0>

Amplitude of the respiration waveform expressed as the change in ohms of the thoracic impedance. "apn"(apnea) means zero amplitude.

apn off on mom > apn 12sec 32sec>

Apnea (no respiration). Various ways to stop breathing. "on" stops breathing continuously. "mom" stops breathing momentarily as long as the execute key is depressed. "12sec" and "32sec" result in apnea for that time period each time execute is depressed. "off" resumes breathing. Note that breathing stops and starts on full breath cycles.

Abnormal Resp

ventilator

A more squared waveform.

Artifact

Ecg Artifact

Adds an extraneous signal to the ecg waveform.

off mscl 50Hz > 60Hz wander >

Selects off, muscular artifact, 50 Hz or 60 Hz interference, or wandering baseline.

ampl x.5 x1 x2

The amplitude factor for ecg artifact, x1 being about 1/2 an R wave amplitude.

lead all RA LA > lead LL V1 >

Allows ecg artifact to be placed on all ecg leads or selectively on only one.

Bp/resp Artifact

Respiration artifact can be injected into any pressure waveform. Arterial and Left Ventricle waveforms are modulated by the selected respiration rate. Modulation on

Arterial is 131/87 to 109/73. Modulation on Left Ventricle is 131/0 to 109/0. All other pressure waveforms have the respiration added to them with a value from 0 to 24 mmHg. The amount of artifact can be x.5 or x1 of the amount specified above.

bp/r off x.5 x1

Enables and selects the amplitude factor for bp/r artifact.

Defibrillator

Note: This is a series of interactive waveforms where the patient goes into fibrillation, and then may be defibrillated either by a pulse signal through the DEFIB SYNC input or by a menu selection. For the emergencies the pulse may come any time during ventricular fibrillation. For Cardioversion, the pulse must be synchronized with the R wave and must come within 100 milliseconds before or after the peak of the R wave. If the pulse comes during this time, the patient will be successfully defibrillated. If the pulse comes outside of this window, the patient will enter ventricular fibrillation. At this point the patient may be defibrillated again back to normal. The waveform for successful defibrillation for all series is a negative pulse which takes 3 seconds to recover to a flat line, then 3 nodal beats at 30 BPM, 6 nodal beats at 60 BPM, and then continuous normal beats at 80 BPM. The waveform for an unsuccessful defibrillation when in Cardioversion is the same negative pulse and 3 second recovery followed by ventricular fibrillation. When using the menu selections, either the original waveform, or the defibrillated result may be selected at any time.

Emergency 1

A series with 10 normal beats, a PVC (R on T), 6 normal beats, another PVC (R on T), and then a continuous fine ventricular fibrillation.

e1 new defib

“new” starts the series. “defib” defibrillates the patient.

Emergency 2

A series with 10 normal beats, 25 beats of ventricular tachycardia (180 BPM), and then a continuous fine ventricular fibrillation.

e2 new defib

“new” starts the series. “defib” defibrillates the patient.

Cardioversion

A course atrial fibrillation waveform which must be defibrillated synchronized with the R wave.

cv new sync late>

“new” starts the waveform. “sync” gives a successful defibrillated result simulating that the pulse came within the +/- 100 millisecond window of the R wave. “late” simulates that the defib pulse was late and came after the window, resulting in ventricular fibrillation.

External input

ext in off on>

Disables or enables pulses at the DEFIB SYNC input to get through to defibrillate the patient.

IABP

Intra-Aortic Balloon Assist Pump

Note: Entering this menu and executing one of the following waveforms sets the BP-1 channel to the arterial waveform and enables it to be modified by a signal from an Intra-Aortic Balloon pump, simulating the pump's effect which is added to the arterial waveform. Early, normal, and late inflation and deflation are simulated. The pump signal enters via the DEFIB SYNC input, a high level indicating that the pump is on. See Specifications.

nsb 30 60 80 120>

Normal sinus rate in BPM.

afib

Atrial fibrillation.

pvc 6/min.

PVC's among normal beats at 6 per minute.

paced async

Asynchronous continuously paced, 75 BPM.

paced demand

Paced on demand, mostly paced.

run 5 pvcs

Five PVC's together among 14 normal beats.

run 11 pvcs

Ten left and one right PVC together among eight normal beats.

Utility

up<—view—>dn

Adjust viewing angle of front panel display for best contrast, saved during power off.

calibrate

Enters the calibration mode. In order to enter the Calibration mode, the Cal enable switch must be depressed. In addition, there is a movable jumper inside the unit that enables or disables calibration (see calibration procedure). It is normally in the disable position.

user off on def>

Turns off or on the user menu or enters the special define user menu mode. See below section on USER MENU.

model 21_ _ _

Displays the model number and the software revision number.

baud 300 600 > baud 1200 2400 >

Sets the baud rate for the RS-232 interface. See below section on RS-232.

echo off on

Determines whether the characters received via the RS-232 port are echoed back to the sender.

POWER UP CONDITIONS

The following conditions are present when the power is first turned on:

ECG: Normal Sinus, 60 BPM, Normal Axis, Adult,
1 mV amplitude, no ST segment variation.

BLOOD PRESSURE: all channels at ATM.

RESPIRATION: Normal, 20 BPM, 1.0 ohms.

ARTIFACT: All off.

USER MENU

Executing "off" disables USER MENU. The USER MENU is then removed from the MAIN MENU list.

Executing "on" enables the user menu if one has been defined. USER MENU will appear in the MAIN MENU. The execute menus under this main menu are executed just like other menus.

Executing "def"(define) places the unit in a special mode where any execute menu that is executed is placed in the USER MENU. The display flashes for a longer time than normal when a function is executed to show that this mode is engaged. The menu can be up to 50 selections long. If more than 50 are entered, the unit automatically exits the define mode. Each time the define mode is exited, the previous USER MENU is destroyed. If the power is turned off before the define mode is exited the new menu will be lost and the previous one remains intact. This can be useful if, while entering a new menu, you want to terminate the entry and go back to the previous menu. UTILITY menus and Blood Pressure 3 menus will not be placed in the USER MENU.

Once a menu has been defined it cannot be modified. The only way to modify the old menu is to completely reenter it.

EXAMPLE:

Set the display to the user define menu ("user off on def"). Set the cursor to "def" and execute it. Now leave the user define menu and execute the following selections:

- 1) ECG, Premature, pac
- 2) BLOOD PRESSURE, Blood pressure 1, wedge
- 3) BLOOD PRESSURE, Blood pressure 2, cvp
- 4) RESPIRATION, Normal Resp, ohms 1.0
- 5) RESPIRATION, Normal Resp, rate 20

Return to the user define menu and execute the "on" cursor position. Now go back to the main menus and find USER MENU. Execute it and the display should read: ecg pac. The sub key will scroll through the rest of the user menu, it should match what was entered above. Any of these menus can be executed by depressing execute.

Return to the user define menu and execute "off". Now return to the main menus and note that the USER MENU is now gone. Turning it back on will bring back the menu previously entered so it does not have to be reentered. The user menu is not lost when the power is turned off.

RS-232

All functions may be programmed via RS-232 except echo and baud rate. See calibration procedure for RS-232 calibration. A special cable is required and is available from Dynatech. There are three standard cables:

3010-0204H: female, pin 2 Txd, IBM compatible
3010-0203H: male, pin 2 Rxd
3010-0202H: male, pin 2 Txd

Pin 2 Txd means transmit to simulator on pin 2, pin 2 Rxd means receive from simulator on pin 2. Connector gender is for connector on cable. Standard length is 6 ft. Special lengths or connector configurations are available.

Baud rate is settable to 300, 600, 1200 or 2400, see UTILITY menu above. The simulator sends a prompt (“>”) on power up. Commands may be entered in lower case or upper case. Spaces are ignored. Commands must be terminated with a carriage return or a line feed. Illegal entries cause an error message to be sent (“?”), including entries which are not possible to set up. Another prompt is sent after the previous message has been executed. Characters may be echoed, see UTILITY menu above. The function entered will be displayed on the front panel display except for certain special commands. Baud rate and Echo are saved when the power is turned off.

Below are the 4 possible messages that the simulator can send:

ECHO OFF, LEGAL COMMAND: >, CR, LF
ECHO OFF, ILLEGAL COMMAND: ?, CR, LF
ECHO ON, LEGAL COMMAND: (command string), CR, LF, >
ECHO ON, ILLEGAL COMMAND:
(command string), ?, CR, LF, >

Echo on is normally for use with terminals, echo off is for use with computers

The escape key will cancel all characters from the previous CR or LF. Backspace will delete the previous character.

Data format is 7 bits and a parity bit. Parity is ignored on input and off (0) for output. Any number of stop bits are accepted, one is output.

Following is a list of RS232 commands:

| Category | Command | Description |
|----------------------|--|--|
| Normal Sinus Rate | NSB30 NSB60 NSB80 NSB120 NSB160 NSB200 NSB240 NSB300 | bpm 30 bpm 60 bpm 80 bpm 120 bpm 160 bpm 200 bpm 240 bpm 300 |
| Normal Sinus Ampl. | NSA0.5 NSA1.0 NSA1.5 NSA2.0 | ampl 0.5 ampl 1.0 ampl 1.5 ampl 2.0 |
| Axis Deviation | AXNRM AXHRZ AXVER | normal axis horizontal axis vertical axis |
| St Segment Variation | STVOFF STVPOS STVNEG STA0.05 STA0.1 STA0.15 STA0.2 STA0.5 STA0.8 | st variation off positive st variation negative st variation .05 st amplitude .1 st amplitude .15 st amplitude .2 st amplitude .5 st amplitude .8 st amplitude |
| Pediatrics | PEDOFF PEDON | pediatrics off pediatrics on |
| ECG Performance | SQU PUL SIN10 SIN40 SIN50 SIN60 SIN100 TRI | sq 2Hz @ 1mV pulse 4sec 1mV sine 10 sine 40 sine 50 sine 60 sine 100 tri 2Hz 3mV |

| | | |
|----------------|--|---|
| SV Arrhythmias | AF1 AF2 AFL SINA MB80 MB120 PAT NOD SVT | afib1 afib2 aflutter sinus arr mb80 mb120 pat nodal svt |
| Premature | PAC PNC PVC1 PVC1E PVC1R PVC2 PVC2E PVC2R MFL | pac pnc pvc1 pvc 1 early pvc 1 r on t pvc 2 pvc 2 early pvc 2 r on t multifocal |
| Vent Rhythms | PVC6 PVC12 PVC24 FMF BIG TRG PAIR RUN5 RUN11 VNT VTC VFB1 VFB2 EMD ASY | pvc6 6/min pvc6 12/min pvc6 24/min freq mf 20/min bigeminy trigeminy pair pvc run 5 pvc6 run 11 pvc6 ventricular vtach vfib 1 vfib 2 emd asystole |
| Conduction | 1DB 2DB1 2DB2 3DB RBB LBB | 1 deg. block 2 deg. block t 1 2 deg. block t 2 3 deg. block rbbb lbbb |

| | | |
|---------------|---|--|
| Paced Rhythms | ASN DM1 DM2 AVS NCA NFU | async 75 bpm demand 1 demand 2 av seq non capture non function |
| BP1 | P1S0 P1ART P1LV P1RV P1PA P1W P1S0 P1S20 P1S40 P1S80 P1S100 P1S200 P1S250 P1S300 | atm arterial left ventricle right ventricle pulm art wedge static 0 static 20 static 40 static 80 static 100 static 200 static 250 static 300 |
| BP2 | P2S0 P2CVP P2RV P2PA P2W P2S0 P2S5 P2S10 P2S20 P2S30 | atm cvp right vent pulm artery wedge static 0 static 5 static 10 static 20 static 30 |
| BP3 | P3ATM P3CVP P3RV P3PA P3W | atm cvp rv pa wedge |
| BP3 Swan-Ganz | INS INF DEF REM | insert inflate deflate remove |

| | | |
|--------------------|--|--|
| Normal Resp. ohms | RO0.0 RO0.1 RO0.2 RO0.5 RO1.0 RO3.0 | ohms apn ohms .1 ohms .2 ohms .5 ohms 1.0 ohms 3.0 |
| Normal Resp. Rate | RR15 RR20 RR30 RR40 RR60 RR120 | rate 15 rate 20 rate 30 rate 40 rate 60 rate 120 |
| Normal Resp. Apnea | AOFF AON A12 A32 | apn off apn on apn 12sec apn 32sec |
| Abnormal Resp. | RVNT | ventilator |
| ecg Artifact | EAOFF EAMSC EA50 EA60 EAWNDR EAAX.5 EAAX1 EAAX2 EALALL EALRA EALLA EALLL EALV1 | ecg art off ecg art mscl ecg art 50Hz ecg art 60Hz ecg art wander ecg art ampl x.5 ecg art ampl x1 ecg art ampl x2 ecg art all leads ecg art lead RA ecg art lead LA ecg art lead LL ecg art lead V1 |
| bp/r Artifact | PAOFF PAX.5 PAX1 | bp/r art off bp/r art ampl x.5 bp/r art ampl x1 |

| | | |
|-------------------------------------|--|--|
| Defibrillator | E1NEW E1DEF E2NEW E2DEF CVNEW CVSYNC CVLATE DFOFF DFON | emergency 1, new emergency 1, defib emergency 2, new emergency 2, defib cardioversion, new cardioversion, sync cardioversion, late ext input disable ext input enable |
| IABP (Intra-Aortic Balloon Pump) | INSB30 INSB60 INSB80 INSB120 IAFIB IPVC6 IPASYNC IPDEM IRPVC5 IRPVC11 | normal sinus 30 bpm normal sinus 60 bpm normal sinus 80 bpm normal sinus 120 bpm atrial fibrillation PVC's 6 per minute paced asynchronous paced on demand run of 5 PVC's run of 11 PVC's |
| Miscellaneous | UOFF UON UDEF KOFF KON | user menu off user menu on user menu define disable front panel keys enable front panel keys |

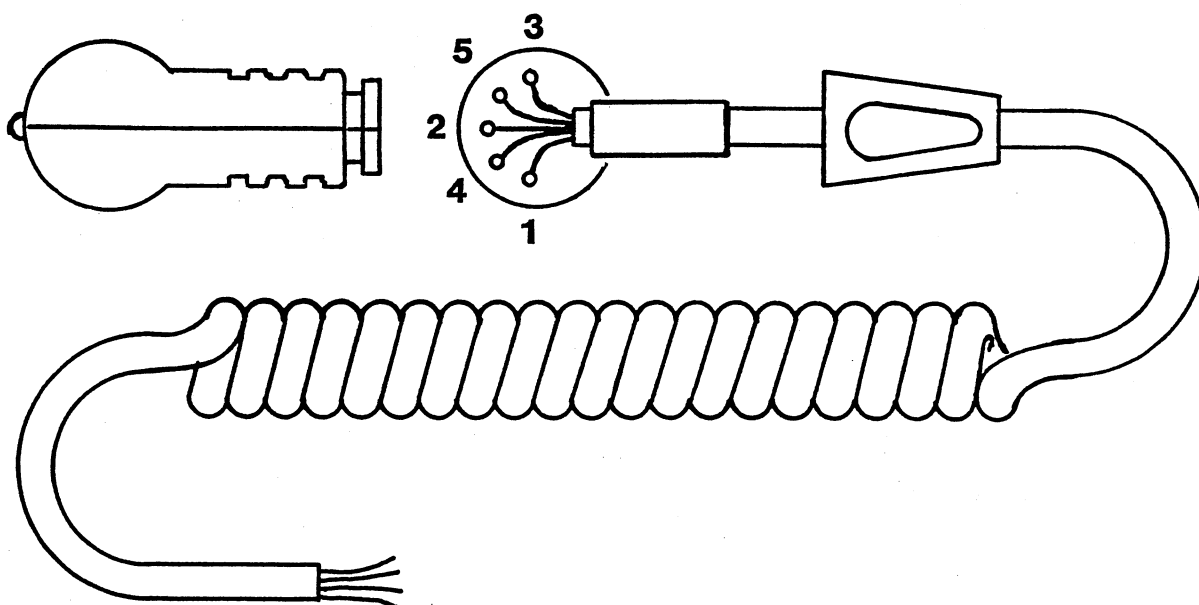

WIRING TABLE

| FUNCTION | COLOR | PIN NO |
|--------------------|--------------|---------------|
| OUTPUT (+) | BLACK | 4 |
| OUTPUT (-) | RED | 1 |
| EXCITER (+) | WHITE | 3 |
| EXCITER (-) | GREEN | 5 |
| ECG REF | BLUE | 2 |

Patient Simulator B.P. OUTPUT CABLE ASSEMBLY

Figure 2.1

CHAPTER 3

CALIBRATION PROCEDURE

CAPACITIVELY COUPLED REAR PANEL CALIBRATION PROCEDURE

Some units have the ECG leads capacitively coupled. This disables the calibration of the ECG AMPLITUDE and RESPIRATION through the rear panel jacks. If the adjustments have no effect when calibrating these two parameters use the following procedure.

Disassemble the unit as for BP OFFSET AND LINEARITY. ECG AMPLITUDE AND RESPIRATION calibration calls for connecting the DMM to LL and RA. Instead connect it to pins 10, and 11 of the rear panel connector as shown below. Then follow the normal procedure.

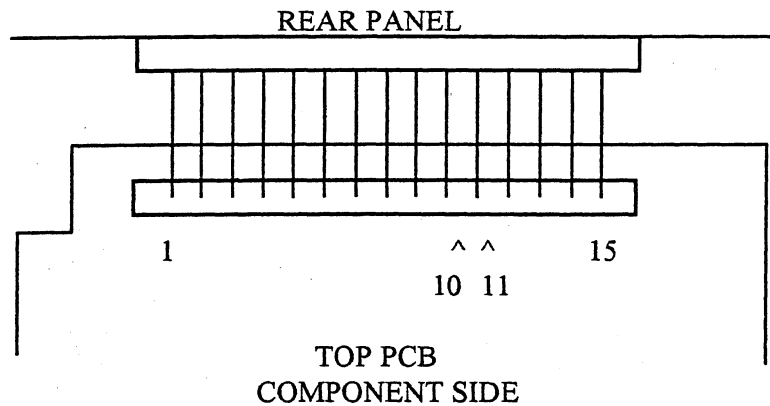

Figure 3.1

INTRODUCTION

To calibrate the simulator the following equipment is required:

MODEL 213:

DIGITAL MULTIMETER 4 1/2 digits

MODELS 215 AND 217:

DIGITAL MULTIMETER 5 1/2 digits
(must resolve .01 Ohm out of 500)

10.000 VOLTAGE SOURCE 30 mAmps.

SPECIAL BP CABLE DNI P.N. 3010-0205H

Calibration can be done via RS-232 or the front panel. Units with capacitively decoupled rear panels require the calibration test leads to be connected to the rear panel connector pins for ECG and RESPIRATION amplitudes. (See Figure 3.1)

There is a jumper inside the unit that disables calibration. See Figure 3.2 for location of jumper. All units except the earliest produced also have a switch to bypass the disable jumper. This switch is located inside a small hole on the right side of the unit under the cal sticker. This switch allows enabling the calibration procedure without disassembling the unit. Depress and hold the switch while executing the calibrate menu to enter the calibration mode.

FRONT PANEL CALIBRATION

RS-232 is disabled during front panel calibration.

The front panel keys are redefined for calibration:

| | |
|------------|----------------------|
| MAIN KEY | increment reading |
| SUB KEY | (special, see below) |
| CURSOR KEY | decrement reading |
| EXC KEY | execute |

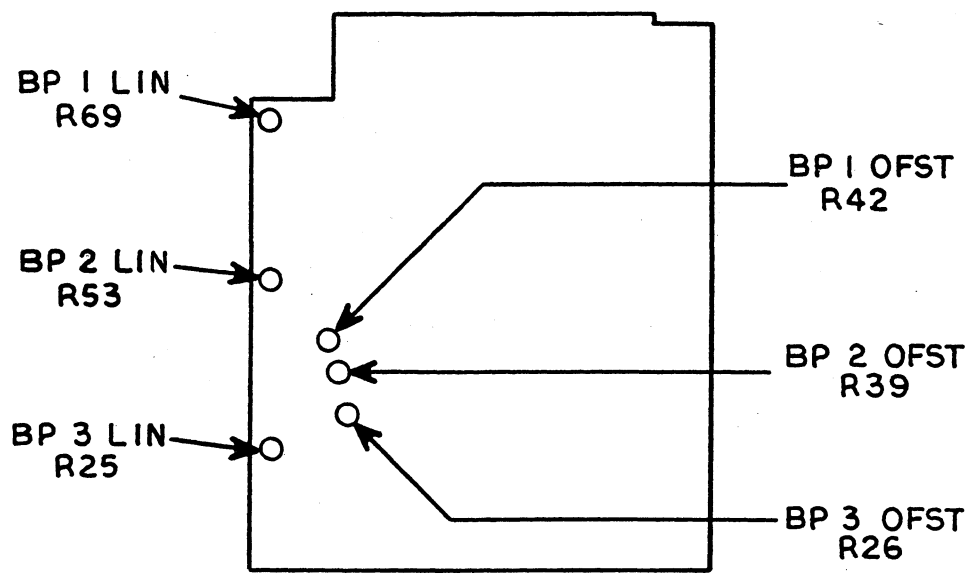

TOP PCB
ADJUSTMENT LOCATIONS

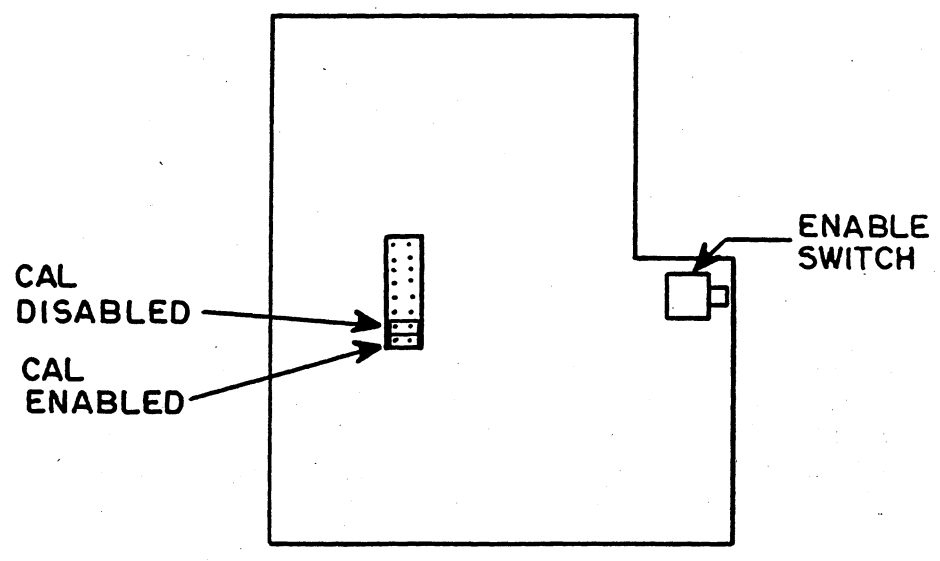

BOTTOM PCB

Figure 3.2

The SUB KEY has two special functions, to jump to a specific step and to exit the cal procedure. Do not use the SUB KEY until after the "RAW CAL? SUB=YES" menu unless a raw cal is desired (see below). To set a specific step number, first depress SUB. The display reads a number with a cursor flashing under the first digit, use the INC and DEC KEYS to set the number to the first number of the step desired. Now press SUB again and the cursor moves over to the second digit, adjust this as desired. Depress SUB again and the unit jumps to the step number displayed. To leave the calibration procedure at any time depress SUB then depress EXC.

In order to calibrate the unit it will be necessary to open the case and remove the top and bottom P.C.boards. The bottom case half is secured by the four screws holding the rubber feet. The bottom board is secured to the top board by three screws. The top board is secured to the case by two hex head screws. Set the PC boards on a non-conductive surface for calibration.

Set the following initial conditions:

| | |
|-------------|-----|
| POWER | ON |
| SENSITIVITY | 40 |
| LEAD SELECT | II |
| BASELINE | 500 |

It is recommended that a battery eliminator be used. If the battery goes low before the last step is performed all calibration data is lost.

Set the display to the calibrate menu under UTILITY. Move the cal jumper to the cal enable position or depress and hold the cal switch and execute the calibrate menu. If the unit has a cal enable switch use it instead of the jumper.

The display now reads "RAW CAL? SUB=YES". This step only needs to be done if the EEPROM, U17, has been replaced. Hit any key except SUB to skip this step. To perform this step depress SUB. This loads raw cal constants into memory.

View Angle

The display now reads "1. VIEWING ANGLE". Use the INC(MAIN) and DEC(CURSOR) keys to set the desired viewing angle. Then depress execute to go to the next step. Note that the first character on the display is a "1", this is the step number. Each step is numbered consecutively on the display. These numbers are different for each model.

Model Number

Step 2 is "2. 213 215 217". Set the correct model number using the DEC key and go to the next step by depressing execute.

BP Offset and Linearity (See Figure 3.2)

The next group of steps are for adjusting blood pressure offset and linearity (6 steps for 217, 4 steps for 215 none for 213). These are internal adjustments. Check the calibration by following the adjustment procedure below without actually adjusting anything to see if the unit is still calibrated.

Connect the cable to BP1. Connect the black lead to DMM high and the red lead to DMM low. Leave the white and green leads open. With the cursor under "OFST" adjust the voltage for 0V +/- 50uV using the adjustment labeled BP1 OFST. Move the cursor to "LIN" and adjust the voltage for 0V +/- 50uV using the adjustment labeled BP1 LIN. Repeat both cursor position steps until both readings are in spec.

Now go to the next step, "4. BP1 A B C D". Step through the four cursor positions checking the voltage at each one. All four reading should be less than 125 uV. If they are not, readjust as follows: if A or B are out adjust OFST, if C or D are out adjust LIN. Then recheck all positions.

Repeat this procedure for BP2 and BP3 using steps 5 through 8 for a 217 or steps 5 and 6 for a 215.

ecg Amplitude

For the next two steps (9 & 10 for 217, 7 & 8 for 215, 3 & 4 for 213) connect the DMM to LL high and RA low. If the unit has a capacitively decoupled rear panel connect the DMM high to pin 10 and low to pin 11 (see Figure 3.1). Adjust for the voltage as shown on the display using the increment and decrement keys.

If calibrating a 213 go to the paragraph marked EXIT.

Respiration

For the next steps (11-15 for 217, 9-13 for 215, none for 213) connect the DMM to LL high and RA low and set the DMM to measure ohms. For the first step measure and record the resistance.

For each of the next 4 steps adjust the resistance to the value measured in the first step plus the signed number on the display. Use a range on the DMM that can resolve .01 ohms out of 500. EXAMPLE: If the reading in the first step is 500 ohms, then in the second step set the ohms to 500.25 ohms.

Blood Pressures

The remaining steps are self explanatory. Connect the special cable to the BP channel shown on the display, connect the white lead to 10 volts with the green lead to ground, connect the black lead to the DMM high and the red lead to the DMM low. Adjust the voltage to the value shown on the display. Repeat this for all remaining steps. The display will prompt you when to switch to the other channels.

Note: The first step on each blood pressure channel is 0 volts. The unit cannot output voltage below the voltage set in the linearity and offset adjustments above, but the decrement key can set a cal value below this resulting in distorted pressure waveforms. To avoid this, decrement the voltage until it does not change any more, note the voltage, increment above it then slowly decrement down to it and stop. Do this only for the first step on each channel.

Exit

After executing the last step, the instrument automatically returns to the normal mode outputting the waveforms it would if the power was just turned on. Return cal jumper to the disable position if desired.

RS-232 CALIBRATION

Before attempting RS-232 calibration become familiar with the FRONT PANEL CALIBRATION procedure above. The front panel is disabled during RS-232 calibration. Refer to the OPERATING INSTRUCTIONS for operation of the RS-232 port. Each step in the calibration has a command. There are 5 commands each for incrementing and decrementing values. These work like the increment and decrement keys except the different commands allow for various inc and dec rates. All steps are displayed except model number. The steps may be done in any order except model number must be done first (and not again) and the two ecg steps must be

done in order (0 then 1mV). If a command is entered that is not appropriate for the instrument being calibrated an error message (“?”) will be returned.

To enter the RS-232 calibration, set the cal jumper or cal switch and enter the command “CAL”. For a raw cal enter the command “INITCAL” instead. At the end of the calibration, “END” must be entered or the data is lost. If the power is turned off during cal the data is lost.

To adjust BP offset and linearity, use OFSETB for offset and OFSETD for linearity. Then check all 4 settings as in the front panel calibration.

Note: For ROM revisions 1.01 to 1.05 “initcal” sets the baud rate to 2400 and turns echo on. This may prevent further communication with your computer. If this is a problem, either perform a rawcal from the front panel or contact the factory for new roms. But under normal conditions it is not necessary to do a raw cal.

EXAMPLE: The objective is to enter the calibration procedure, adjust BP-1 ATM then leave. The instrument is a 217.

- 1) Set the cal jumper or depress and hold the cal switch while entering ‘CAL’ on RS-232.
- 2) Enter “M217”. Model no.
- 3) Enter “1P0”. Blood pressure channel 1, 0 mV.
- 4) Read the DMM. Enter INC and DEC commands until the meter reads 0mV.
- 5) Enter “END”. This exits the calibration procedure.

Below is a list of RS-232 calibration commands:

| Function | Command | Description |
|-------------------|---|---|
| Viewangle | VIEW | view angle |
| Model Number | M213 M215 M217 | model 213 model 215 model 217 |
| BP Offset and Lin | OFSTA OFSTB OFSTC OFSTD | offset a offset b offset c offset d |
| ECG | ECG0 ECG1 | ecg 0 mV ecg 1 mV |
| Respiration | RREF R+.25 R-.25 R+1.5 R-1.5 | reference ohms ref +.25 ohms ref -.25 ohms ref +1.5 ohms ref -1.5 ohms |
| BP1 | 1P0 1P.8 1P4 1P8 1P10 1P16 1P32 1P40 1P48 1P80 1P100 1P120 | 0 mV .8 mV 4 mV 8 mV 10 mV 16 mV 32 mV 40 mV 48 mV 80 mV 100 mV 120 mV |
| BP2 | 2P0 2P.8 2P2 2P2.8 2P4 2P6 2P8 2P10 2P12 | 0 mV .8 mV 2 mV 2.8 mV 4 mV 6 mV 8 mV 10 mV 12 mV |

| Function | Command | Description |
|-----------------|--|---|
| BP3 | 3P0 3P.8 3P2.8 3P4 3P6 3P10 | 0 mV .8 mV 2.8 mV 4 mV 6 mV 10 mV |
| Increment | INCS INCM INCL INCX INCXX | increment INCS x 8 INCS x 64 INCS x 512 INCS x 4096 |
| Decrement | DECS DECM DECL DECX DECXX | decrement DECS x 8 DECS x 64 DECS x 512 DECS x 4096 |
| Exit | END | leave cal |

CHAPTER 4

CIRCUIT DESCRIPTION

BLOCK DIAGRAM DESCRIPTION (FIGURE 4.1)

The block diagram is shown in Figure 4.1. The microcomputer receives inputs from the keyboard to set the display and the desired waveforms for ECG, blood pressure, respiration, and viewing angle. There are 15 separate outputs from the instrument. To generate all of them the microcomputer continually scans through all 15 to update the analog output levels as follows: The digital to analog converter is set to the level for the channel being processed then the appropriate sample and hold channel is open and after the hold capacitor is charged up it is closed again. This is repeated for the next channel and so on until all channels are updated. This cycle is repeated continuously. The sample and hold channels hold the levels until the next update cycle.

The signals out of the sample and hold circuits are in the order of 1 volt. The ECG attenuator reduces these to the 1 mvolt level for the ECG posts. The 1 VOLT OUTPUT is left at a high level. The blood pressure signals are processed through circuitry that multiplies them by the extiter voltage from the patient monitor to generate the output signal. The respiration signal is converted from a varying voltage to a varying resistance at the appropriate ECG lead. The viewing angle signal is sent to the display to set the viewing angle.

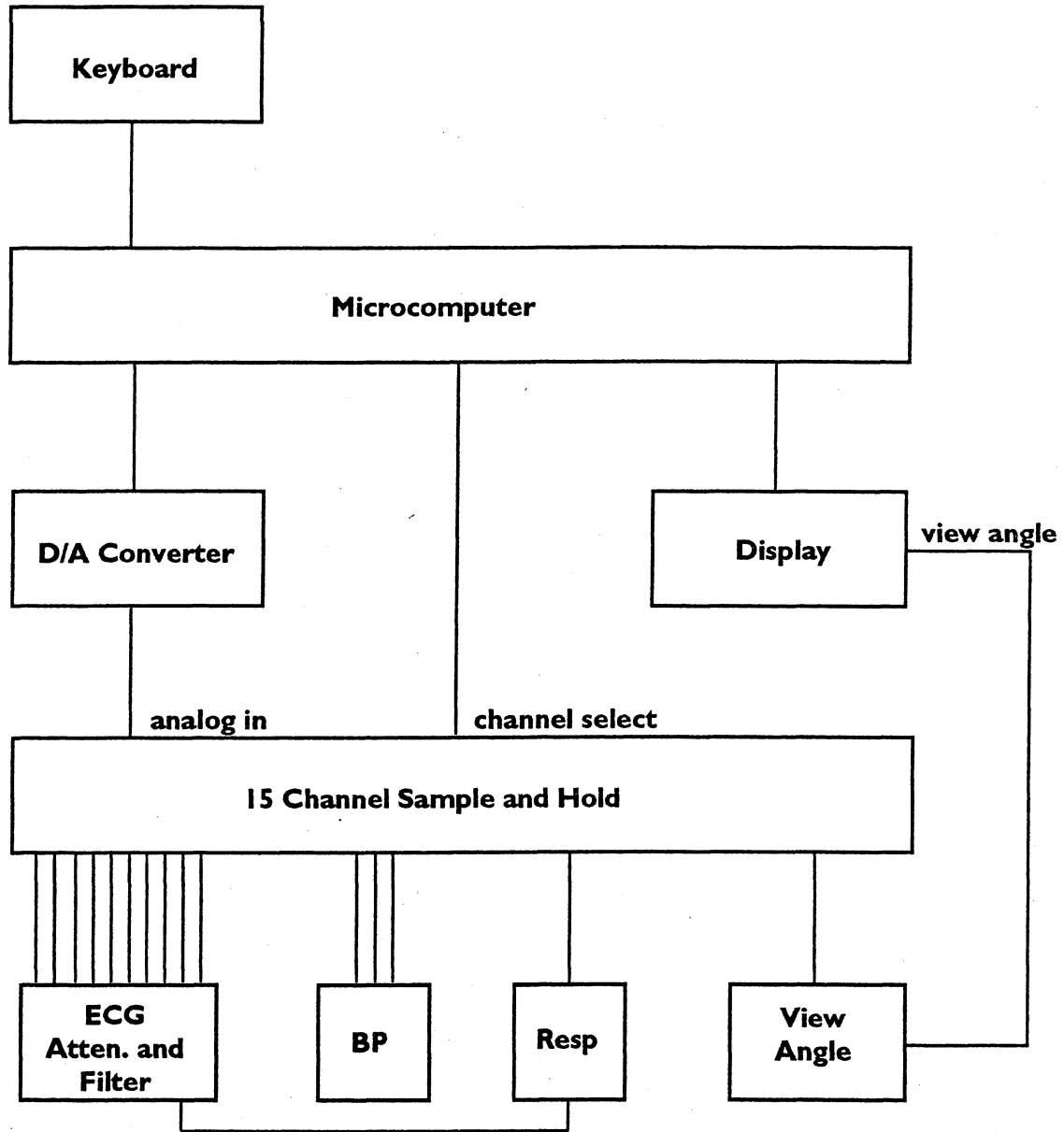

Figure 4.1
Block Diagram

SCHEMATIC 1

The processing unit of the micro computer, U11, is an HD6303. This device has an 8 bit micro processor, 2 timers, 256 bytes of RAM, a serial port and 5 I/O ports. The ports have been configured as follows: 2 ports form the address buss; 1 port for the data buss; 1 port for the keyboard, cal disable switch, low battery signal from the power supply and the defib sync input; 1 port for sample and hold channel selection, ECG filter on/off and EEROM control.

The keyboard (schematic 5) is 4 keys, MAIN, SUB, CURSOR, and EXECUTE. These are described in the operation procedure in Chapter 2. The calibration procedure is stored in PROM and can be accessed from the keyboard. If a jumper is placed a position 9 of J3 the calibration is disabled unless the CAL DISABLE switch is depressed. Calibration constants are stored in a nonvolatile memory (EEROM), U17. Each time the unit is powered up the processor turns on the EEROM by turning on Q4. The data is read into RAM and then the EEROM is turned off to save power. U17 has a bidirectional serial data line at pin 5. Data transfer is synchronized by the clock, from the processor, at pin 6. There is 64k of PROM, U12 and U13, containing the program for the unit. The bottom 8k of ROM is not used because it overlaps the 8k RAM, U14.

The serial port on the processor is used for the RS-232 port. U10a converts the incoming signal from the high level bipolar signal to a 0-5 volt signal for the processor. U10b takes the transmit signal from the processor and translates it into a ± 3 volt signal. U10c senses low level defibrillator signals and converts them to levels for the processor. It has a trip point of .4 volts.

SCHEMATIC 2

The unit can be powered by a battery or a battery eliminator. This is regulated to +5 volts and -5 volts. U16 is the +5 volt regulator. It is a low power voltage regulator with built in current limiting. When the input voltage is low for the regulator to regulate, about 5.5 volts, the ERR line is pulled low to signal the processor to terminate output waveforms and display LOW BATTERY. Q3 takes the raw voltage and shifts it to approximately +5 volts to drive the voltage inverter, U15. U15 converts +5 to -5 volts. It is not a voltage regulator and also has a 50 Ω output resistance.

U9 is a 12 bit D/A converter with internal data storage registers. Both registers are accessed from the 8 bit data buss from the processor. Output waveforms have 8 bit resolution. The other 4 bits are for software adjustment of amplitude and offset. The calibration

procedure calculates offset and amplitude constants for each output that are included in the data sent to the D/A. U8 converts the current output of U9 to a voltage with a range of 0 to 2.4 volts. U10d amplifies this to 4.8 volts. The 2.4 volt reference voltage from U6b is also summed into U10d to shift the output to have a range of +2.4 to -2.4 volts. U6a buffers the 1.2 volts from U10 to be used as the reference voltage for the D/A converter, U9. U6b amplifies this to 2.4 volts.

The various IC's in the instrument that are connected to the data buss have chip select inputs that must be set in order for them to receive data. These are generated from the address buss by U2, U3, U4 and U5.

SCHEMATIC 3

U5 through U10 form the 15 channel sample and hold circuit. U9 and U10 are 1 input to 8 output analog switches. The select inputs A, B and C select which output is connected to the input. Each chip also has an INHibit input. By using the select and inhibit inputs the processor can route the analog signal from the D/A converter to any of the outputs (see block diagram description). Each of these channels has a capacitor to hold the voltage after the channel has been deselected, and a high input impedance amplifier to buffer the capacitor. Nine of the resulting signals form the ECG outputs. These are attenuated by the resistor networks RN1, RN2 and RN4. Between RN1 and RN2, each channel has a capacitor to filter out frequencies above 100 Hz. These smooth out the steps from the D/A converter. Each capacitor is connected to an analog switch, U11, U12 and U13. These turn the filter off to allow pacer spikes through to the output when they are selected.

The 1 VOLT ECG output is generated by U6a. This also has a switchable filter at its input.

The respiration signal sample and hold is U5d. This is sent to U4b to be converted to a varying resistance. In the feedback of U4b is an LED and photo resistor, PR1a. The output of U4b sets the amount of current into the LED and thus its light output. This in turn sets the resistance of the photo resistor. Thus the resistance of the photo resistor tracks the input signal. PR1a and PR1b are a matched set. The current in both diodes is equal so the resistance of both photo resistors is the same. The resistor in PR1b is connected in series with an ECG output. The LEAD switch selects which ECG post has the respiration signal on it.

The viewing angle control voltage is generated at U5c and routed to the display on schematic 5.

The 3 blood pressure waveforms are generated at U9c, U5a and U5d. These are routes to the blood pressure output circuitry on schematic 4.

SCHEMATIC 4

The three blood pressure channels are identical except for differences in pressure range. Only one will be described. U3b is a transconductance amplifier. It has a differential input and a bias input. The output is the product of these two inputs. The exciter voltage input from the blood pressure patient monitor at J1 pins 3 and 5 is routed to the voltage input of U3b after being attenuated by R60 and R59, and R63 and R78. The blood pressure signal for BP1 from the sample and hold on schematic 3 is converted from a voltage to a current by U4a and Q3 and routed to the bias input of U3b. The output of U3b is thus the blood pressure signal times the exciter voltage. The attenuator at the output sets the output voltage at J3 pins 1 and 4. The voltage can be set to simulate either 5 or 40 $\mu\text{V}/\text{V}/\text{mmHg}$ by the sensitivity switch.

The 2 temperature outputs are a set of resistors that simulate the resistance of a temperature thermistor.

SCHEMATIC 5

This schematic shows the interconnects between all the circuit boards and the connections to the front rear and top panels.

CHAPTER 5

PARTS LIST

| REF. DES. | PART NO. | DESCRIPTION | QTY |
|-----------------------------|-----------|-----------------------------|-----|
| 213A SHIPPING SYSTEM | | | |
| ZZ1 | 9519-0122 | 213 FINAL ASSY | 1 |
| ZZ2 | 9508-0161 | 217 MANUAL | 1 |
| ZZ3 | 1201-0019 | BATTERY ELIM 211A | 1 |
| ZZ4 | 9301-0034 | SHIPPING BOX | 1 |
| ZZ5 | 9530-0014 | 217 CARRING CASE | 1 |
| ZZ6 | 1001-2001 | BATTERY 9 VOLT | 1 |
| ZZ7 | NO P/No. | 3 X 5 PLASTIC BAG | 1 |
| 213A FINAL ASSEMBLY | | | |
| B001 | - | NOT USED | 1 |
| J030 | 2719-0203 | JACK PHONE | 1 |
| P001 | 2710-0331 | 2 PIN CONN 0.1" SPACING | 1 |
| ZZ01 | 5205-0203 | 213 TOP PCB ASSY | 1 |
| ZZ02 | 5205-0194 | 217 BOTTOM PCB ASSY | 1 |
| ZZ03 | 5210-0132 | 217 RR PNL EL ASSY | 1 |
| ZZ05 | 5001-0190 | 217 FRONT PANEL | 1 |
| ZZ06 | 5027-0068 | 217 DISPLAY LENS | 1 |
| ZZ10 | 4904-0007 | FOOT RUBBER BOTTOM | 4 |
| ZZ11 | 4709-0004 | SCREW METRIC 3m X 30m PPH | 4 |
| ZZ12 | 5023-0071 | BATTERY COMPARTMENT | 1 |
| ZZ13 | 4715-0021 | SCREW 4-20 X 9/16 HEX WSHER | 2 |
| ZZ14 | 4704-2234 | SCREW 4-40 X 5/16 PPH | 5 |
| ZZ16 | 4711-0115 | WASHER INT/TH #4 | 9 |
| ZZ18 | 8006-0001 | LOCKTITE CA-9 | A/R |
| ZZ19 | 3003-0500 | WIRE 24G PVC BLK 2in | 1 |
| ZZ20 | 3003-0502 | WIRE 24G PVC RED 2 in | 1 |
| ZZ21 | 5027-0069 | 217 CASE TOP MODIFIED | 1 |
| ZZ22 | 5027-0070 | 217 CASE BOTTOM MODIFIED | 1 |
| ZZ24 | 5001-0196 | 213 TOP DATA PANEL | 1 |
| ZZ26 | 4711-4015 | WASHER FLAT #4 | 4 |

| REF. DES. | PART NO. | DESCRIPTION | QTY |
|-----------------------------|-----------|----------------------|-----|
| 213 TOP PCB ASSEMBLY | | | |
| C003 | 0418-0008 | CAP CERM .1uF | 1 |
| C004 | 0418-0008 | CAP CERM .1uF | 1 |
| C013 | 0418-0073 | CAP CERM .0047uF | 1 |
| C014 | 0418-0073 | CAP CERM .0047uF | 1 |
| C015 | 0418-0073 | CAP CERM .0047uF | 1 |
| C016 | 0418-0073 | CAP CERM .0047uF | 1 |
| C018 | 0418-0073 | CAP CERM .0047uF | 1 |
| C019 | 0418-0073 | CAP CERM .0047uF | 1 |
| C020 | 0418-0073 | CAP CERM .0047uF | 1 |
| C022 | 0418-0073 | CAP CERM .0047uF | 1 |
| C023 | 0418-0073 | CAP CERM .0047uF | 1 |
| C024 | 0418-0073 | CAP CERM .0047uF | 1 |
| C026 | 0418-0073 | CAP CERM .0047uF | 1 |
| C028 | 0415-0104 | CAP MICA 150pF | 1 |
| C029 | 0418-0008 | CAP CERM .1uF | 1 |
| C030 | 0418-0008 | CAP CERM .1uF | 1 |
| C031 | 0418-0072 | CAP CERM .015uF | 1 |
| C033 | 0418-0008 | CAP CERM .1uF | 1 |
| C034 | 0418-0072 | CAP CERM .015uF | 1 |
| C035 | 0418-0072 | CAP CERM .015uF | 1 |
| C036 | 0418-0072 | CAP CERM .015uF | 1 |
| C038 | 0418-0072 | CAP CERM .015uF | 1 |
| C039 | 0418-0072 | CAP CERM .015uF | 1 |
| C040 | 0418-0008 | CAP CERM .1uF | 1 |
| C041 | 0418-0008 | CAP CERM .1uF | 1 |
| J004 | 2710-0168 | M HEADER 2PIN | 1 |
| J005 | 2710-0172 | M HEADER RA 15 PIN | 1 |
| J006 | 2710-0167 | M HEADER 26 PIN SIP | 1 |
| J009 | 2710-0170 | JACK DIN I/O 5 PIN | 1 |
| J010 | 2710-0170 | JACK DIN I/O 5 PIN | 1 |
| R036 | 0300-1107 | RES 1/4W 5% 10M | 1 |
| R085 | 0307-1683 | RES MF 1/8W 1% 4.99K | 1 |
| R086 | 0307-1434 | RES MF 1/8W 1% 27.4k | 1 |
| R090 | 0307-1731 | RES MF 1/8W 1% 56.2 | 1 |
| R091 | 0307-1731 | RES MF 1/8W 1% 56.2 | 1 |
| R093 | 0307-1731 | RES MF 1/8W 1% 56.2 | 1 |
| R094 | 0307-1242 | RES 1/8W 1% 174 | 1 |
| R095 | 0307-1242 | RES 1/8W 1% 174 | 1 |
| R096 | 0307-1242 | RES 1/8W 1% 174 | 1 |
| R126 | 0300-1106 | RES 1/4W 5% 1M | 1 |
| R128 | 0307-1934 | RES MF 1/8W 1% 90.9K | 1 |
| R129 | 0300-1203 | RES 1/4W 5% 2K | 1 |
| R130 | UNUSED | RES UNUSED | 1 |

| REF. DES. | PART NO. | DESCRIPTION | QTY |
|------------------------------------|-----------|----------------------|-----|
| 213 TOP PCB ASSEMBLY, cont. | | | |
| RN01 | 0317-0026 | RES NET 220K X8 DIP | 1 |
| RN02 | 0317-0025 | RES NET 150K X7 DIP | 1 |
| RN03 | 0317-0028 | RES NET 470 X7 SIP | 1 |
| RN04 | 0317-0023 | RES NET 22K X7 DIP | 1 |
| RN05 | 0317-0022 | RES NET 270 X7 DIP | 1 |
| S004 | 2507-0018 | SWITCH SLIDE 4P2T | 1 |
| U005 | 2118-0114 | IC LF444CN | 1 |
| U006 | 2118-0114 | IC LF444CN | 1 |
| U007 | 2118-0114 | IC LF444CN | 1 |
| U008 | 2118-0114 | IC LF444CN | 1 |
| U009 | 2121-0079 | IC MC74HC4051 | 1 |
| U010 | 2121-0079 | IC MC74HC4051 | 1 |
| U011 | 2121-0054 | IC 74HC4316N | 1 |
| U012 | 2121-0054 | IC 74HC4316N | 1 |
| U013 | 2121-0054 | IC 74HC4316N | 1 |
| W001 | 3015-0005 | JUMPER .4 INSL | 1 |
| ZZ01 | 4910-0095 | STANDOFF .75 4-40 SW | 3 |
| ZZ02 | 2712-0003 | SOCKET DIP 8 PIN | 2 |
| ZZ03 | 2712-0015 | SOCKET DIP 14 PIN | 8 |
| ZZ04 | 2712-0018 | SOCKET DIP 16 PIN | 7 |
| ZZ05 | 2714-0002 | TEST POINT | 2 |
| ZZ06 | 4910-0097 | SW STD #6 RD .25L | 2 |
| ZZ07 | 5201-0199 | 217 TOP PCB | 1 |

| REF. DES. | PART NO. | DESCRIPTION | QTY |
|----------------------------|-----------|----------------------------|-----|
| 215 SHIPPING SYSTEM | | | |
| ZZ06 | 1001-2001 | BATTERY 9 VOLT | 1 |
| ZZ07 | NO P/No. | 3 X 5 PLASTIC BAG | 1 |
| ZZ1 | 1201-0019 | BATTERY ELIM 211A | 1 |
| ZZ2 | 9301-0034 | SHIPPING BOX | 1 |
| ZZ3 | 9508-0161 | 217 MANUAL | 1 |
| ZZ4 | 9519-0123 | 215 FINAL ASSY | 1 |
| ZZ5 | 9530-0014 | 217 CARRING CASE | 1 |
| 215 FINAL ASSEMBLY | | | |
| B001 | - | NOT USED | 1 |
| J030 | 2719-0203 | JACK PHONE | 1 |
| P001 | 2710-0331 | 2 PIN CONN 0.1" SPACING | 1 |
| ZZ01 | 5205-0193 | 215 TOP PCB ASSY | 1 |
| ZZ02 | 5205-0194 | 217 BOTTOM PCB ASSY | 1 |
| ZZ03 | 5210-0144 | 217 RR PNL EL ASSY | 1 |
| ZZ05 | 5001-0190 | 217 FRONT PANEL | 1 |
| ZZ06 | 5027-0068 | 217 DISPLAY LENS | 1 |
| ZZ10 | 4904-0007 | FOOT RUBBER BOTTOM | 4 |
| ZZ11 | 4709-0004 | SCREW METRIC 3m X 30m PPH | 4 |
| ZZ12 | 5023-0071 | BATTERY COMPARTMENT | 1 |
| ZZ13 | 4715-0021 | SCREW 4-40 X 9/16 HEX WSHR | 2 |
| ZZ14 | 4704-2234 | SCREW 4-40 X 5/16 PPH | 5 |
| ZZ16 | 4711-0115 | WASHER INT/TH #4 | 9 |
| ZZ18 | 8006-0001 | LOCTITE CA-9 | A/R |
| ZZ19 | 3003-0500 | WIRE 24G PVC BLK 2in | 1 |
| ZZ20 | 3003-0502 | WIRE 24G PVC RED 2 in | 1 |
| ZZ21 | 5027-0069 | 217 CASE TOP MODIFIED | 1 |
| ZZ22 | 5027-0070 | 217 CASE BOTTOM MODIFIED | 1 |
| ZZ25 | 5001-0197 | 215 TOP DATA PANEL BASIC | 1 |
| ZZ26 | 4711-4015 | WASHER FLAT #4 | 4 |

| REF. DES. | PART NO. | DESCRIPTION | QTY |
|--|-----------|---------------------|-----|
| 215 TOP PCB ASSEMBLY (#104140, Rev M) | | | |
| C001 | 0418-0071 | CAP CERM .56uF | 1 |
| C002 | 0418-0016 | CAP CERM .001uF | 1 |
| C003 | 0418-0008 | CAP CERM .1uF | 1 |
| C004 | 0418-0008 | CAP CERM .1uF | 1 |
| C005 | 0418-0071 | CAP CERM .56uF | 1 |
| C006 | 0418-0071 | CAP CERM .56uF | 1 |
| C008 | 0418-0008 | CAP CERM .1uF | 1 |
| C011 | 0418-0073 | CAP CERM .0047uF | 1 |
| C013 | 0418-0073 | CAP CERM .0047uF | 1 |
| C014 | 0418-0073 | CAP CERM .0047uF | 1 |
| C015 | 0418-0073 | CAP CERM .0047uF | 1 |
| C016 | 0418-0073 | CAP CERM .0047uF | 1 |
| C018 | 0418-0073 | CAP CERM .0047uF | 1 |
| C019 | 0418-0073 | CAP CERM .0047uF | 1 |
| C020 | 0418-0073 | CAP CERM .0047uF | 1 |
| C021 | 0418-0008 | CAP CERM .1uF | 1 |
| C022 | 0418-0073 | CAP CERM .0047uF | 1 |
| C023 | 0418-0073 | CAP CERM .0047uF | 1 |
| C024 | 0418-0073 | CAP CERM .0047uF | 1 |
| C025 | 0418-0008 | CAP CERM .1uF | 1 |
| C026 | 0418-0073 | CAP CERM .0047uF | 1 |
| C028 | 0415-0104 | CAP MICA 150 pF | 1 |
| C029 | 0418-0008 | CAP CERM .1uF | 1 |
| C030 | 0418-0008 | CAP CERM .1uF | 1 |
| C031 | 0418-0072 | CAP CERM .015uF | 1 |
| C033 | 0418-0008 | CAP CERM .1uF | 1 |
| C034 | 0418-0072 | CAP CERM .015uF | 1 |
| C035 | 0418-0072 | CAP CERM .015uF | 1 |
| C036 | 0418-0072 | CAP CERM .015uF | 1 |
| C038 | 0418-0072 | CAP CERM .015uF | 1 |
| C039 | 0418-0072 | CAP CERM .015uF | 1 |
| C040 | 0418-0008 | CAP CERM .1uF | 1 |
| C041 | 0418-0008 | CAP CERM .1uF | 1 |
| C042 | 0418-0008 | CAP CERM .1uF | 1 |
| D001 | 2102-0034 | TRANSORB 5V SA5.0 | 1 |
| J001 | 2710-0169 | JACK DIN BP 5 PIN | 1 |
| J002 | 2710-0169 | JACK DIN BP 5 PIN | 1 |
| J004 | 2710-0168 | M HEADER 2PIN | 1 |
| J005 | 2710-0172 | M HEADER RA 15 PIN | 1 |
| J006 | 2710-0167 | M HEADER 26 PIN SIP | 1 |
| J007 | 2710-0171 | JACK DIN TEMP 4 PIN | 1 |
| J008 | 2710-0171 | JACK DIN TEMP 4 PIN | 1 |
| J009 | 2710-0170 | JACK DIN I/O 5 PIN | 1 |
| J010 | 2710-0170 | JACK DIN I/O 5 PIN | 1 |

| REF. DES. | PART NO. | DESCRIPTION | QTY |
|---|-----------|-----------------------|-----|
| 215 TOP PCB ASSEMBLY (#104140, Rev M), cont. | | | |
| PR01 | 2116-0016 | PHOTO ISO MATCHED (2) | 1 |
| Q001 | 2112-0023 | TRANS 2N 4250 | 1 |
| Q002 | 2112-0023 | TRANS 2N 4250 | 1 |
| Q003 | 2112-0023 | TRANS 2N 4250 | 1 |
| R001 | 0316-0199 | RES 1/8W .1% 332 | 1 |
| R003 | 0316-0200 | RES 1/8W 0.1% 2.32K | 1 |
| R004 | 0307-1563 | RES 1/8W 1% 3.74K | 1 |
| R005 | 0307-1852 | RES 1/8W 1% 750 | 1 |
| R006 | 0316-0199 | RES 1/8W .1% 332 | 1 |
| R008 | 0307-1174 | RES 1/8W 1% 14.7K | 1 |
| R009 | 0307-1685 | RES 1/8W 1% 499K | 1 |
| R010 | 0307-1884 | RES 1/8W 1% 80.6K | 1 |
| R011 | 0307-1685 | RES 1/8W 1% 499K | 1 |
| R013 | 0307-1334 | RES 1/8W 1% 21.5K | 1 |
| R014 | 0307-1475 | RES 1/8W 1% 301K | 1 |
| R015 | 0307-1764 | RES 1/8W 1% 60.4K | 1 |
| R016 | 0307-1355 | RES 1/8W 1% 226K | 1 |
| R018 | 0307-1182 | RES 1/8W 1% 150 | 1 |
| R019 | 0307-1182 | RES 1/8W 1% 150 | 1 |
| R020 | 0307-1355 | RES 1/8W 1% 226K | 1 |
| R021 | 0307-1764 | RES 1/8W 1% 60.4K | 1 |
| R023 | 0307-1015 | RES MF 1/8W 1% 100K | 1 |
| R024 | 0307-1015 | RES MF 1/8W 1% 100K | 1 |
| R025 | 0326-0018 | RES VAR 1M | 1 |
| R026 | 0326-0014 | RES VAR 100K | 1 |
| R028 | 0307-1764 | RES 1/8W 1% 60.4K | 1 |
| R029 | 0316-0199 | RES 1/8W .1% 332 | 1 |
| R030 | 0316-0199 | RES 1/8W .1% 332 | 1 |
| R031 | 0316-0200 | RES 1/8W 0.1% 2.32K | 1 |
| R033 | 0307-1563 | RES 1/8W 1% 3.74K | 1 |
| R034 | 0307-1852 | RES 1/8W 1% 750 | 1 |
| R035 | 0307-1182 | RES 1/8W 1% 150 | 1 |
| R036 | 0300-1107 | RES 1/4W 5% 10M | 1 |
| R038 | 0307-1083 | RES 1/8W 1% 1.18K | 1 |
| R039 | 0326-0014 | RES VAR 100K | 1 |
| R040 | 0307-1475 | RES 1/8W 1% 301K | 1 |
| R041 | 0307-1355 | RES 1/8W 1% 226K | 1 |
| R042 | 0326-0128 | RES VAR 100K | 1 |
| R043 | 0307-1083 | RES 1/8W 1% 1.18K | 1 |
| R044 | 0307-1182 | RES 1/8W 1% 150 | 1 |
| R045 | 0307-1764 | RES 1/8W 1% 60.4K | 1 |
| R046 | 0307-1355 | RES 1/8W 1% 226K | 1 |
| R048 | 0307-1174 | RES 1/8W 1% 14.7K | 1 |
| R049 | 0307-1685 | RES 1/8W 1% 499K | 1 |

| REF. DES. | PART NO. | DESCRIPTION | QTY |
|---|-----------|----------------------|-----|
| 215 TOP PCB ASSEMBLY (#104140, Rev M), cont. | | | |
| R050 | 0307-1884 | RES 1/8W 1% 80.6K | 1 |
| R051 | 0307-1685 | RES 1/8W 1% 499K | 1 |
| R053 | 0326-0018 | RES VAR 1M | 1 |
| R054 | 0307-1334 | RES 1/8W 1% 21.5K | 1 |
| R055 | 0307-1182 | RES 1/8W 1% 150 | 1 |
| R056 | 0307-1182 | RES 1/8W 1% 150 | 1 |
| R058 | 0307-1765 | RES 1/8W 1% 604K | 1 |
| R059 | 0307-1764 | RES 1/8W 1% 60.4K | 1 |
| R060 | 0307-1355 | RES 1/8W 1% 226K | 1 |
| R061 | 0307-1852 | RES 1/8W 1% 750 | 1 |
| R063 | 0307-1355 | RES 1/8W 1% 226K | 1 |
| R064 | 0307-1174 | RES 1/8W 1% 14.7K | 1 |
| R065 | 0307-1685 | RES 1/8W 1% 499K | 1 |
| R066 | 0307-1884 | RES 1/8W 1% 80.6K | 1 |
| R068 | 0307-1685 | RES 1/8W 1% 499K | 1 |
| R069 | 0326-0129 | RES VAR 1M | 1 |
| R070 | 0316-0200 | RES 1/8W 0.1% 2.32K | 1 |
| R071 | 0300-1103 | RES 1/4W 5% 1K | 1 |
| R073 | - | UNUSED | 0 |
| R074 | 0316-0199 | RES 1/8W .1% 332 | 1 |
| R075 | 0316-0199 | RES 1/8W .1% 332 | 1 |
| R076 | 0307-1334 | RES 1/8W 1% 21.5K | 1 |
| R078 | 0307-1764 | RES 1/8W 1% 60.4K | 1 |
| R079 | 0307-1295 | RES 1/8W 1% 196K | 1 |
| R080 | 0307-1775 | RES MF 1/8W 1% 619K | 1 |
| R081 | 0307-1234 | RES 1/8W 1% 16.9K | 1 |
| R083 | 0307-1663 | RES MF 1/8W 1% 4.75K | 1 |
| R084 | 3015-0005 | JUMPER .4 INSL | 1 |
| R085 | 0307-1683 | RES MF 1/8W 1% 4.99K | 1 |
| R086 | 0307-1434 | RES MF 1/8W 1% 27.4K | 1 |
| R088 | 0307-1302 | RES 1/8W 1% 200 | 1 |
| R089 | 0307-1242 | RES 1/8W 1% 174 | 1 |
| R090 | 0307-1731 | RES MF 1/8W 1% 56.2 | 1 |
| R091 | 0307-1731 | RES MF 1/8W 1% 56.2 | 1 |
| R093 | 0307-1731 | RES MF 1/8W 1% 56.2 | 1 |
| R094 | - | (USED IN 213 ONLY) | |
| R095 | - | (USED IN 213 ONLY) | |
| R096 | 0307-1242 | RES 1/8W 1% 174 | 1 |
| R098 | 0307-1301 | RES MF 1/8W 1% 20 | 1 |
| R099 | 0316-0197 | RES 1/8W 0.5% 1.18K | 1 |
| R100 | 0307-1532 | RES MF 1/8W 1% 348 | 1 |
| R101 | 0316-0191 | RES 1/8W 0.5% 15.8K | 1 |
| R103 | 0307-1602 | RES MF 1/8W 1% 412 | 1 |
| R104 | 0316-0190 | RES 1/8W 0.5% 17.8K | 1 |

| REF. DES. | PART NO. | DESCRIPTION | QTY |
|---|-----------|----------------------|-----|
| 215 TOP PCB ASSEMBLY (#104140, Rev M), cont. | | | |
| R105 | 0307-1391 | RES MF 1/8W 1% 24.9 | 1 |
| R106 | 0316-0196 | RES 1/8W 0.5% 1.33K | 1 |
| R108 | 0307-1531 | RES MF 1/8W 1% 34.8 | 1 |
| R109 | 0316-0195 | RES 1/8W 0.5% 1.78K | 1 |
| R110 | 0307-1541 | RES MF 1/8W 1% 35.7 | 1 |
| R111 | 0316-0194 | RES 1/8W 0.5% 3.16K | 1 |
| R113 | 0307-1742 | RES MF 1/8W 1% 576 | 1 |
| R114 | 0316-0189 | RES 1/8W 0.5% 23.7K | 1 |
| R115 | 0307-1591 | RES MF 1/8W 1% 40.2 | 1 |
| R116 | 0316-0193 | RES 1/8W 0.5% 3.57K | 1 |
| R118 | 0307-1901 | RES MF 1/8W 1% 84.5 | 1 |
| R119 | 0316-0192 | RES 1/8W 0.5% 4.75K | 1 |
| R120 | 0316-0190 | RES 1.8W 0.5% 17.8K | 1 |
| R121 | 0316-0193 | RES 1/8W 0.5% 3.57K | 1 |
| R122 | 0316-0196 | RES 1/8W 0.5% 1.33K | 1 |
| R123 | 0307-1602 | RES MF 1/8W 1% 412 | 1 |
| R124 | 0307-1591 | RES MF 1/8W 1% 40.2 | 1 |
| R125 | 0307-1391 | RES MF 1/8W 1% 24.9 | 1 |
| R126 | 0300-1106 | RES CF 1/4W 5% 1M | 1 |
| R128 | 0307-1934 | RES MF 1/8W 1% 90.9K | 1 |
| R129 | 0300-1203 | RES 1/4W 5% 2K | 1 |
| R130 | - | RES UNUSED | |
| RN01 | 0317-0026 | RES NET 220K X7 DIP | 1 |
| RN02 | 0317-0025 | RES NET 150K X 7 DIP | 1 |
| RN03 | 0317-0028 | RES NET 470 X7 SIP | 1 |
| RN04 | 0317-0023 | RES NET 22K X7 DIP | 1 |
| RN05 | 0317-0022 | RES NET 270 X7 DIP | 1 |
| S001 | 2507-0018 | SWITCH SLIDE 4P2T | 1 |
| S002 | 2507-0018 | SWITCH SLIDE 4P2T | 1 |
| S003 | 2507-0018 | SWITCH SLIDE 4P2T | 1 |
| S004 | 2507-0018 | SWITCH SLIDE 4P2T | 1 |
| S005 | 2507-0019 | SWITCH SLIDE 4P3T | 1 |
| U002 | 2118-0116 | IC LF442CN | 1 |
| U003 | 2118-0117 | IC LM13600AN | 1 |
| U004 | 2118-0116 | IC LF442CN | 1 |
| U005 | 2118-0114 | IC LF444CN | 1 |
| U006 | 2118-0114 | IC LF444CN | 1 |
| U007 | 2118-0114 | IC LF444CN | 1 |
| U008 | 2118-0114 | IC LF444CN | 1 |
| U009 | 2121-0079 | IC MC74HC4051 | 1 |
| U010 | 2121-0079 | IC MC74HC4051 | 1 |
| U011 | 2121-0054 | IC 74HC4316N | 1 |
| U012 | 2121-0054 | IC 74HC4316N | 1 |
| U013 | 2121-0054 | IC 74HC4316N | 1 |

| REF. DES. | PART NO. | DESCRIPTION | QTY |
|---|-----------|---------------------------|-----|
| 215 TOP PCB ASSEMBLY (#104140, Rev M), cont. | | | |
| W01 | 3015-0005 | JUMPER .4 INSL | 1 |
| ZZ01 | 4910-0095 | STANDOFF .75 4-40 SW | 3 |
| ZZ02 | 2712-0003 | SOCKET DIP 8 PIN | 2 |
| ZZ03 | 2712-0015 | SOCKET DIP 14 PIN | 8 |
| ZZ04 | 2712-0018 | SOCKET DIP 16 PIN | 7 |
| ZZ05 | 2714-0002 | TEST POINT | 2 |
| ZZ06 | 4910-0097 | SW STD #6 RD .25L | 2 |
| ZZ07 | 5201-0199 | 217 TOP PCB | 1 |
| ZZ08 | 5001-0372 | LABEL BAR CODE SERIALIZED | 1 |

| REF. DES. | PART NO. | DESCRIPTION | QTY |
|---|-----------|----------------------------|-----|
| 217 SHIPPING SYSTEM | | | |
| ZZ1 | 9519-0120 | 217 FINAL ASSY | 1 |
| ZZ2 | 9508-0161 | 217 MANUAL | 1 |
| ZZ3 | 1201-0019 | BATTERY ELIM 211A | 1 |
| ZZ4 | 9301-0034 | SHIPPING BOX | 1 |
| ZZ5 | 9530-0014 | 217 CARRING CASE | 1 |
| ZZ6 | 1001-2001 | BATTERY 9 VOLT | 1 |
| ZZ7 | NO P/No. | 3 X 5 PLASTIC BAG | 1 |
| 217 FINAL ASSEMBLY (104137, Rev H) | | | |
| B001 | - | NOT USED | 1 |
| J001 | 2710-0169 | JACK DIN BP 5 PIN | 1 |
| J030 | 2719-0203 | JACK PHONE | 1 |
| P001 | 2710-0331 | 2 PIN CONN 0." SPACING | 1 |
| U001 | 2118-0117 | TOP PCB U1 LM13600AN | 1 |
| ZZ01 | 5205-0193 | 215 TOP PCB ASSY | 1 |
| ZZ02 | 5205-0194 | 217 BOTTOM PCB ASSY | 1 |
| ZZ03 | 5210-0144 | 217 RR PNL EL ASSY | 1 |
| ZZ05 | 5001-0190 | 217 FRONT PANEL | 1 |
| ZZ06 | 5027-0068 | 217 DISPLAY LENS | 1 |
| ZZ07 | 5001-0192 | 217 TOP DATA PANEL BASIC | 1 |
| ZZ10 | 4904-0007 | FOOT RUBBER BOTTOM | 4 |
| ZZ11 | 4709-0004 | SCREW METRIC 3m X 30m PPH | 4 |
| ZZ12 | 5023-0071 | BATTERY COMPARTMENT | 1 |
| ZZ13 | 4715-0021 | SCREW 4-20 X 9/16 HEX WSHR | 2 |
| ZZ14 | 4704-2234 | SCREW 4-40 X 5/16 PPH | 5 |
| ZZ16 | 4711-0115 | WASHER INT/TH #4 | 5 |
| ZZ18 | 8006-0001 | LOCTITE CA-9 | A/R |
| ZZ19 | 3003-0500 | WIRE 24G PVC BLK 2in | 1 |
| ZZ20 | 3003-0502 | WIRE 24G PVC RED 2in | 1 |
| ZZ21 | 5027-0069 | 217 CASE TOP MODIFIED | 1 |
| ZZ22 | 5027-0070 | 217 CASE BOTTOM MODIFIED | 1 |
| ZZ23 | 4711-4019 | WASHER FLAT #6 | 4 |
| ZZ26 | 4711-4015 | WASHER FLAT #4 | 4 |

| REF. DES. | PART NO. | DESCRIPTION | QTY |
|--------------------------------|-----------|----------------------------|-----|
| 217 REAR PANEL ASSEMBLY | | | |
| C001 | 0401-0014 | CAP DIP 22MF 16V | 1 |
| C002 | 0401-0014 | CAP DIP 22MF 16V | 1 |
| C003 | 0401-0014 | CAP DIP 22MF 16V | 1 |
| C004 | 0401-0014 | CAP DIP 22MF 16V | 1 |
| C005 | 0401-0014 | CAP DIP 22MF 16V | 1 |
| C006 | 0401-0014 | CAP DIP 22MF 16V | 1 |
| C007 | 0401-0014 | CAP DIP 22MF 16V | 1 |
| C008 | 0401-0014 | CAP DIP 22MF 16V | 1 |
| C009 | 0401-0014 | CAP DIP 22MF 16V | 1 |
| C010 | 0401-0014 | CAP DIP 22MF 16V | 1 |
| C011 | 0401-0014 | CAP DIP 22MF 16V | 1 |
| C012 | 0401-0014 | CAP DIP 22MF 16V | 1 |
| C013 | 0401-0014 | CAP DIP 22MF 16V | 1 |
| C014 | 0401-0014 | CAP DIP 22MF 16V | 1 |
| C015 | 0401-0014 | CAP DIP 22MF 16V | 1 |
| C016 | 0401-0014 | CAP DIP 22MF 16V | 1 |
| C017 | 0401-0014 | CAP DIP 22MF 16V | 1 |
| C018 | 0401-0014 | CAP DIP 22MF 16V | 1 |
| J001 | 2710-0163 | CONN SIP F HEAD 15 PIN | 1 |
| R001 | 0300-1106 | RES CC 1/4W 5% 1M Ω | 1 |
| R002 | 0300-1106 | RES CC 1/4W 5% 1M Ω | 1 |
| R003 | 0300-1106 | RES CC 1/4W 5% 1M Ω | 1 |
| R004 | 0300-1106 | RES CC 1/4W 5% 1M Ω | 1 |
| R005 | 0300-1106 | RES CC 1/4W 5% 1M Ω | 1 |
| R006 | 0300-1106 | RES CC 1/4W 5% 1M Ω | 1 |
| R007 | 0300-1106 | RES CC 1/4W 5% 1M Ω | 1 |
| R008 | 0300-1106 | RES CC 1/4W 5% 1M Ω | 1 |
| R009 | 0300-1106 | RES CC 1/4W 5% 1M Ω | 1 |
| ZZ01 | 5201-0217 | REAR PANEL PCB BASIC | 1 |

| REF. DES. | PART NO. | DESCRIPTION | QTY |
|---------------------------------|-----------|-----------------------|-----|
| 217A BOTTOM PCB ASSEMBLY | | | |
| C001 | 0418-0008 | CAP CERM .1uF | 1 |
| C003 | 0418-0008 | CAP CERM .1uF | 1 |
| C004 | 0415-0100 | CAP MICA 100pF | 1 |
| C005 | 0415-0012 | CAP MICA 18pF | 1 |
| C006 | 0418-0008 | CAP CERM .1uF | 1 |
| C008 | 0418-0008 | CAP CERM .1uF | 1 |
| C009 | 0418-0008 | CAP CERM .1uF | 1 |
| C010 | 0415-0012 | CAP MICA 18pF | 1 |
| C011 | 0418-0008 | CAP CERM .1uF | 1 |
| C013 | 0415-0012 | CAP MICA 18pF | 1 |
| C014 | 0403-0019 | CAP ELECT 47uF | 1 |
| C015 | 0418-0008 | CAP CERM .1uF | 1 |
| C016 | 0418-0008 | CAP CERM .1uF | 1 |
| C018 | 0418-0008 | CAP CERM .1uF | 1 |
| C019 | 0418-0008 | CAP CERM .1uF | 1 |
| C020 | 0403-0052 | CAP ELECT 6.8uF | 1 |
| C021 | 0403-0019 | CAP ELECT 47uF | 1 |
| C023 | 0403-0019 | CAP ELECT 47uF | 1 |
| C024 | 0418-0016 | CAP CERM .001uF | 1 |
| C025 | 0401-0005 | CAP CERA 6.8 UF | 1 |
| C026 | 0403-0052 | CAP ELECT 6.8uF | 1 |
| D001 | 2101-0010 | DIODE 1N914 | 1 |
| D002 | 2101-0010 | DIODE 1N914 | 1 |
| D003 | 2101-0010 | DIODE 1N914 | 1 |
| D004 | 2101-0010 | DIODE 1N914 | 1 |
| D005 | 2101-0010 | DIODE 1N914 | 1 |
| D006 | 2101-0010 | DIODE 1N914 | 1 |
| D008 | 2101-0010 | DIODE 1N914 | 1 |
| D009 | 2101-0010 | DIODE 1N914 | 1 |
| D010 | 2102-0039 | LM385Z-1.2 VOLT. REF. | 1 |
| D011 | 2101-0010 | DIODE 1N914 | 1 |
| D014 | 2102-0034 | DIODE 1N6267 OR 5.0A | 1 |
| D015 | 2102-0034 | DIODE 1N6267 OR 5.0A | 1 |
| D016 | 2102-0034 | DIODE 1N6267 OR 5.0A | 1 |
| D017 | 2102-0034 | DIODE 1N6267 OR 5.0A | 1 |
| J001 | 2710-0174 | HEADER F 14 PIN SIP | 1 |
| J002 | 2710-0173 | HEADER F 5 PIN SIP | 1 |
| J003 | 2710-0165 | CONN M HEAD 4 PIN | 1 |
| J004 | 2710-0165 | CONN M HEAD 4 PIN | 1 |
| Q001 | 2111-0007 | TRANS 2N4123 | 1 |
| Q002 | 2111-0007 | TRANS 2N4123 | 1 |
| Q003 | 2111-0007 | TRANS 2N4123 | 1 |
| Q004 | 2112-0003 | TRANS 2N4125 | 1 |

| REF. DES. | PART NO. | DESCRIPTION | QTY |
|--|-----------|----------------------------|-----|
| 217A BOTTOM PCB ASSEMBLY, cont. | | | |
| R001 | 0300-1206 | RES CF 5% 1/4W 2M | 1 |
| R003 | 0300-1102 | RES CF 5% 1/4W 100 | 1 |
| R004 | 0307-1016 | RES CF 1/8W 1% 1.0M | 1 |
| R005 | 0307-1884 | RES MF 1/8W 1% 80.6K | 1 |
| R006 | 0300-1475 | RES CF 1/4W 5% 470K | 1 |
| R008 | 0300-1515 | RES CF 1/4W 5% 510K | 1 |
| R009 | 0300-1105 | RES CF 1/4W 5% 100K | 1 |
| R010 | 0300-1363 | RES CF 5% 1/4W 3.6K | 1 |
| R011 | 0300-1105 | RES CF 1/4W 5% 100K | 1 |
| R013 | 0300-1305 | RES CF 1/4W 5% 300K | 1 |
| R014 | 0300-1105 | RES CF 1/4W 5% 100K | 1 |
| R015 | 0300-1165 | RES CF 1/4W 5% 160K | 1 |
| R016 | 3015-0005 | JUMPER .4INSL | 1 |
| R018 | 0300-1683 | RES CF 1/4W 5% 6.8K | 1 |
| R019 | 0300-1104 | RES CF 1/4W 5% 10K | 1 |
| R020 | 0300-1105 | RES CF 1/4W 5% 100K | 1 |
| R021 | 0300-1513 | RES CF 1/4W 5% 5.1K | 1 |
| R023 | 0300-1244 | RES 1/4W 5% 24K | 1 |
| R024 | 0300-1105 | RES CF 1/4W 5% 100K | 1 |
| R028 | 0300-1823 | RES CF 1/4W 5% 8.2K | 1 |
| R029 | 0300-1823 | RES CF 1/4W 5% 8.2K | 1 |
| RN01 | 0317-0026 | RES NET DIP 220K X8 | 1 |
| RN02 | 0317-0016 | RES NET SIP 4.7K X7 | 1 |
| S001 | 2505-0057 | SW M. SPDT PB | 1 |
| U001 | 2121-0050 | IC MM74HC04N | 1 |
| U002 | 2121-0064 | IC MM74HC02N | 1 |
| U003 | 2121-0065 | IC MM74HC27N | 1 |
| U004 | 2121-0066 | IC MM74HC00N | 1 |
| U005 | 2121-0065 | IC MM74HC27N | 1 |
| U006 | 2118-0116 | IC LF442CN | 1 |
| U008 | 2118-0115 | IC LF441ACN | 1 |
| U009 | 2122-0064 | IC DAC1232LCJ | 1 |
| U010 | 2118-0114 | IC LF444CN | 1 |
| U011 | 2122-0061 | IC HD6303X | 1 |
| U012 | 2122-0069 | IC EPROM PRGMD U12 | 1 |
| U013 | 2122-0070 | IC EPROM PROGMD U13 | 1 |
| U014 | 2122-0054 | IC HM6264LP-15 | 1 |
| U015 | 2118-0113 | IC ICL7660CPA | 1 |
| U016 | 2118-0112 | IC LP2951CN | 1 |
| U017 | 2122-0062 | IC X2404P | 1 |
| Y001 | 1220-0012 | XTAL 4MHz | 1 |
| ZZ01 | 2710-0166 | SHORTING PLUG | 3 |
| ZZ02 | 3010-0188 | 217 CABLE PCB INTERCONNECT | 1 |

| REF. DES. | PART NO. | DESCRIPTION | QTY |
|--|-----------------|--------------------------|------------|
| 217A BOTTOM PCB ASSEMBLY, cont. | | | |
| ZZ03 | 5201-0200 | 217 BOTTOM PCB BASIC | 1 |
| ZZ06 | 2712-0003 | SOCKET DIP 8 PIN | 5 |
| ZZ07 | 2712-0015 | SOCKET DIP 14 PIN | 7 |
| ZZ08 | 2712-0023 | SOCKET DIP 28 PIN | 3 |
| ZZ09 | 2712-0037 | SOCKET 64 PIN 6303 | 1 |
| ZZ10 | 2712-0017 | SOCKET DIP 20 PIN | 1 |
| ZZ11 | 2714-0002 | TEST POINT | 3 |
| ZZ12 | 5205-0195 | 217 FRONT PANEL PCB ASSY | 1 |
| ZZ13 | 4704-2234 | SCREW 4-40 X 5/16 | 1 |
| ZZ14 | 4711-0115 | WASHER #4 INT/THD | 3 |
| ZZ15 | 4711-4013 | WASHER #4 FLAT | 3 |

CHAPTER 6

**COMPONENT LOCATOR
AND SCHEMATICS**

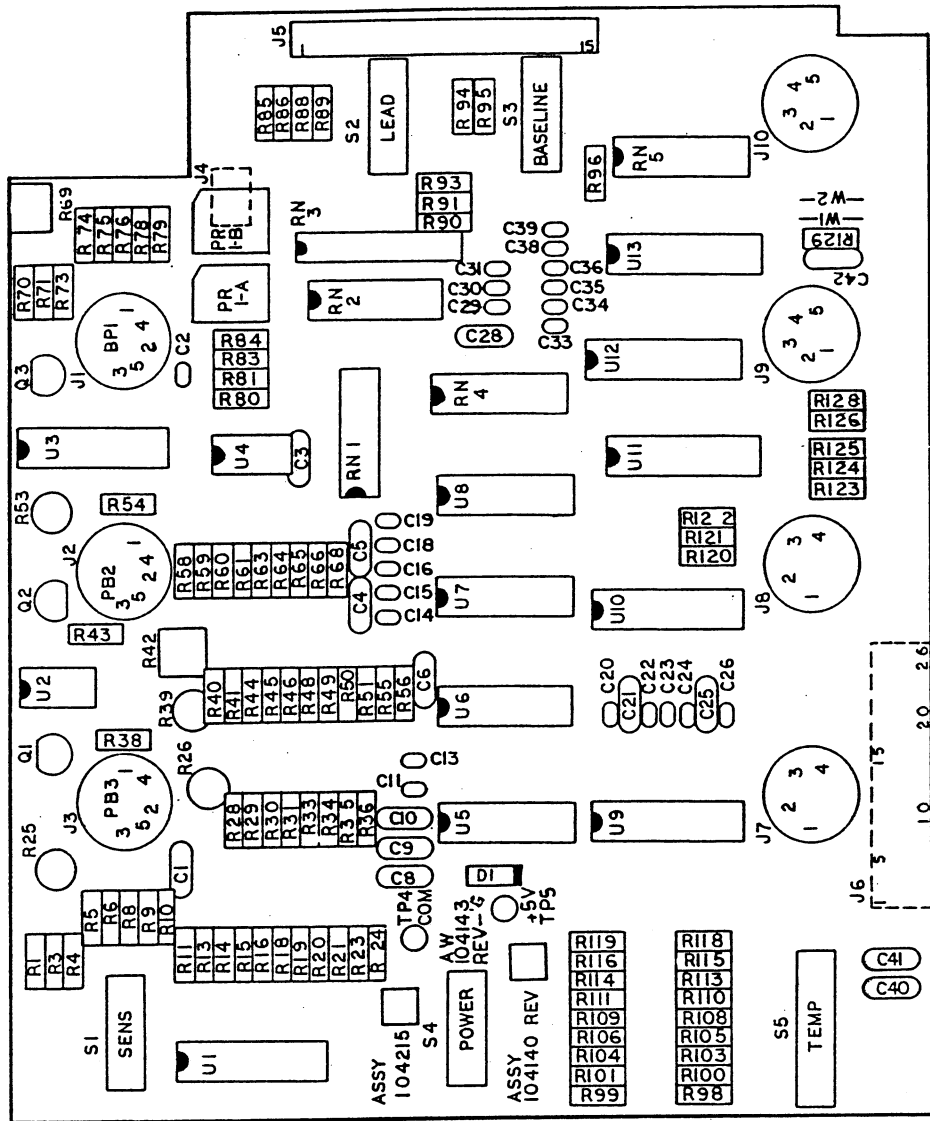

TOP PCB COMPONENT LOCATOR

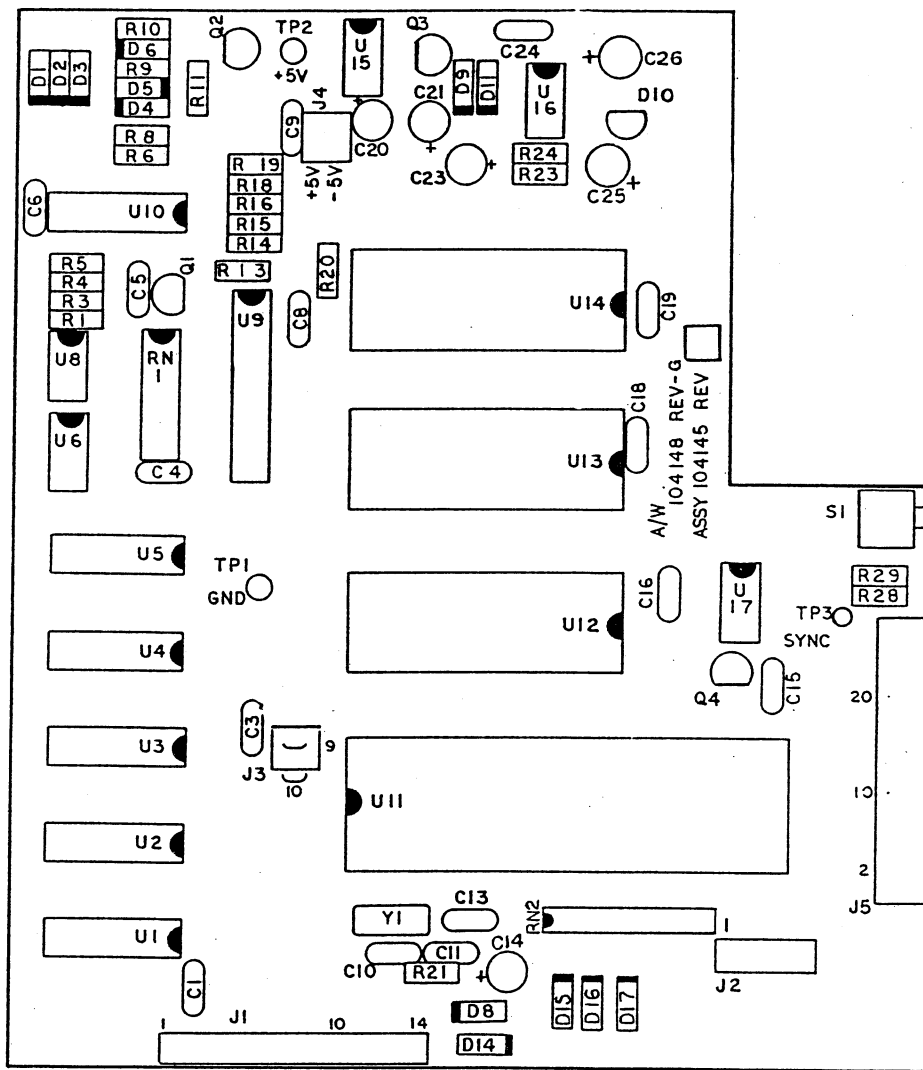

BOTTOM PCB COMPONENT LOCATOR

CHAPTER 7

ADDENDA

DAMAGE and SHORTAGE

Before you fully unpack any unit **READ THIS** for your protection.

(This information applies only to shipments within the United States).

DAMAGE

This shipment was packaged and delivered to the carrier with the utmost care to insure safe delivery of goods. When shipment is received and signed for by the transportation company, consignor's responsibility ceases. Do not accept shipment which evidences damage or shortage until agent of carrier endorses a statement of the irregularity on the face of the transportation receipt. Without documentary evidence, a claim cannot be filed.

CONCEALED DAMAGE

The Interstate Commerce Commission has indicated that a carrier is as much responsible for concealed damage as for visible damage in transit. Upon receipt of shipment, promptly unpack it and check thoroughly. If concealed damage is discovered, cease further unpacking and request immediate inspection by local agent of carrier. A written report of the agent's findings, with signature, is necessary to support claim.

SHORTAGE

Check shipment against shipping papers. Do not discard packing materials or packing cases until contents have been found to be correct. The removal of items before shipment has been checked may create a shortage. Check all possibilities before reporting a shortage.

CLAIMS

If your agent or carrier has been given an opportunity to inspect the shipment, any claim for a shortage or damaged merchandise can be handled as a simple and routine procedure. Claims must be filed by consignee. Shipping terms are F.O.B. Carson City, Nevada unless otherwise specified.

LOSS

In the event of complete loss, claim will be handled in the same manner as for Shipping Damage or Shortage.

SHIPPING DAMAGE / SHORTAGE

AIR FREIGHT

A claim must be initiated at point of destination. A claim must be filed by submitting a letter on company stationery with an explanation of the extent of damage or loss and forwarded with a copy of the original* air bill, and original invoice or photostat of same, to the airline which carried the shipment.

*Upon request, photostatic copies of original papers held by Dynatech Nevada required in support of claims will be made available.

PARCEL POST / UPS

PLACING CLAIM FOR DAMAGE

For those shipments insured by Parcel Post, the addressee initiates the claim by filling out Post Office Dept. Form 3812, "Request for Payment of Domestic Postal Insurance". Item 12 is to be other than Post Office of Address for inspection. A new purchase order is required by Dynatech Nevada to cover the cost of repairs (or in the case of loss or refiling-replacement order). Damaged material will be repaired and returned. Party named in item 12 of form 3812 will receive reimbursement for repair cost from Post Office Department.

PLACING CLAIM FOR LOSS

In the event of a report to consignor of loss or refiling, Post Office Department Form 3812 will be initiated by Dynatech Nevada at point of origin. If, after Post Office investigation, the material is not located, disposition from this point will be the same as stated in the previous paragraph - "Placing claim for damage".

PLACING CLAIM FOR DAMAGE TO SHIPMENTS BY UNITED PARCEL

The addressee must notify Dynatech Nevada, who will notify United Parcel Service giving the shipper's number and date parcel was shipped. United Parcel Service will send a representative to inspect the damage and advise proper disposition. A new purchase order is required by Dynatech Nevada to cover the cost of repairs or in the case of loss or refiling, a replacement order. Damaged material will be repaired and returned.

217 MENU MAP ROM VERSION 2.0

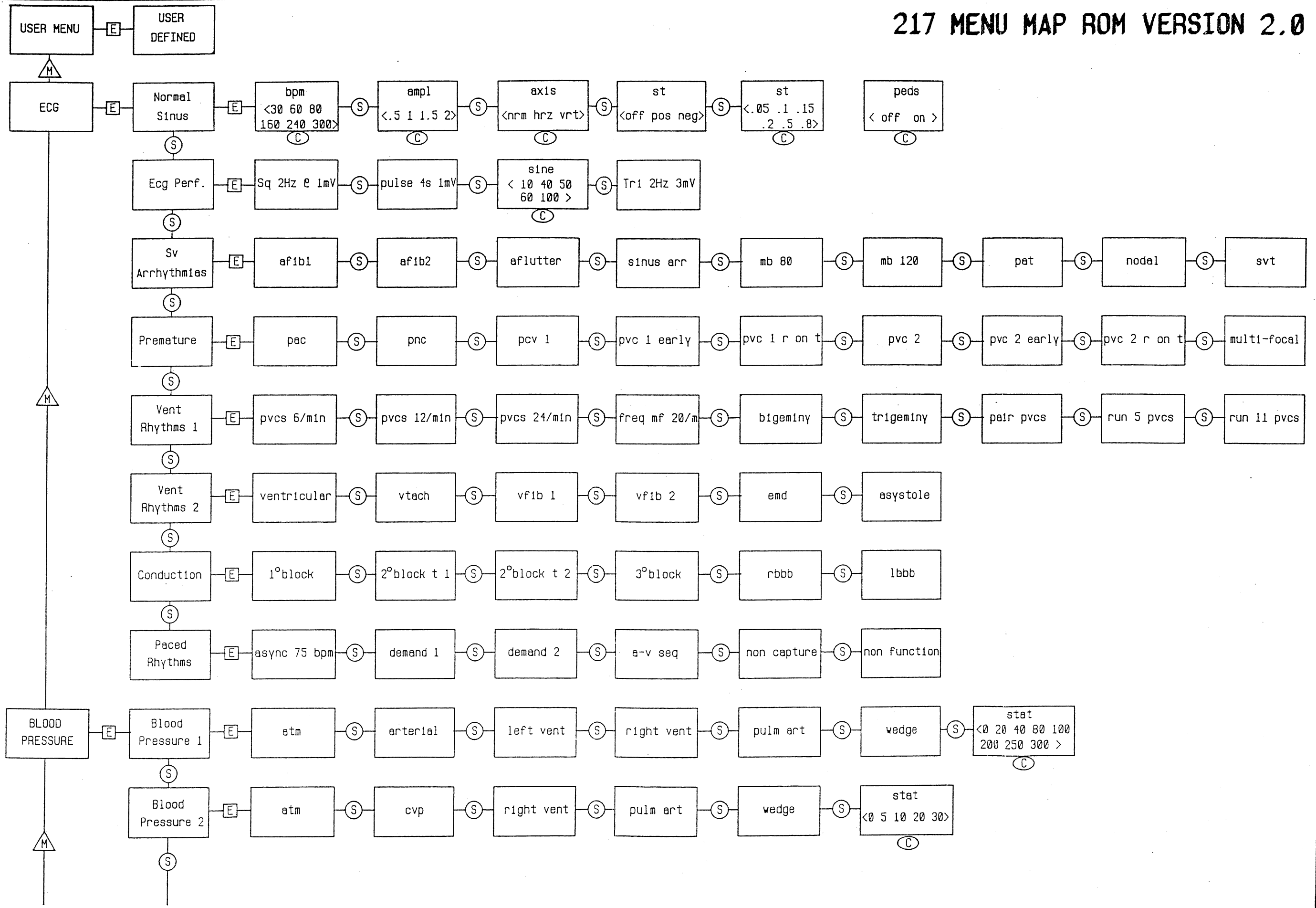

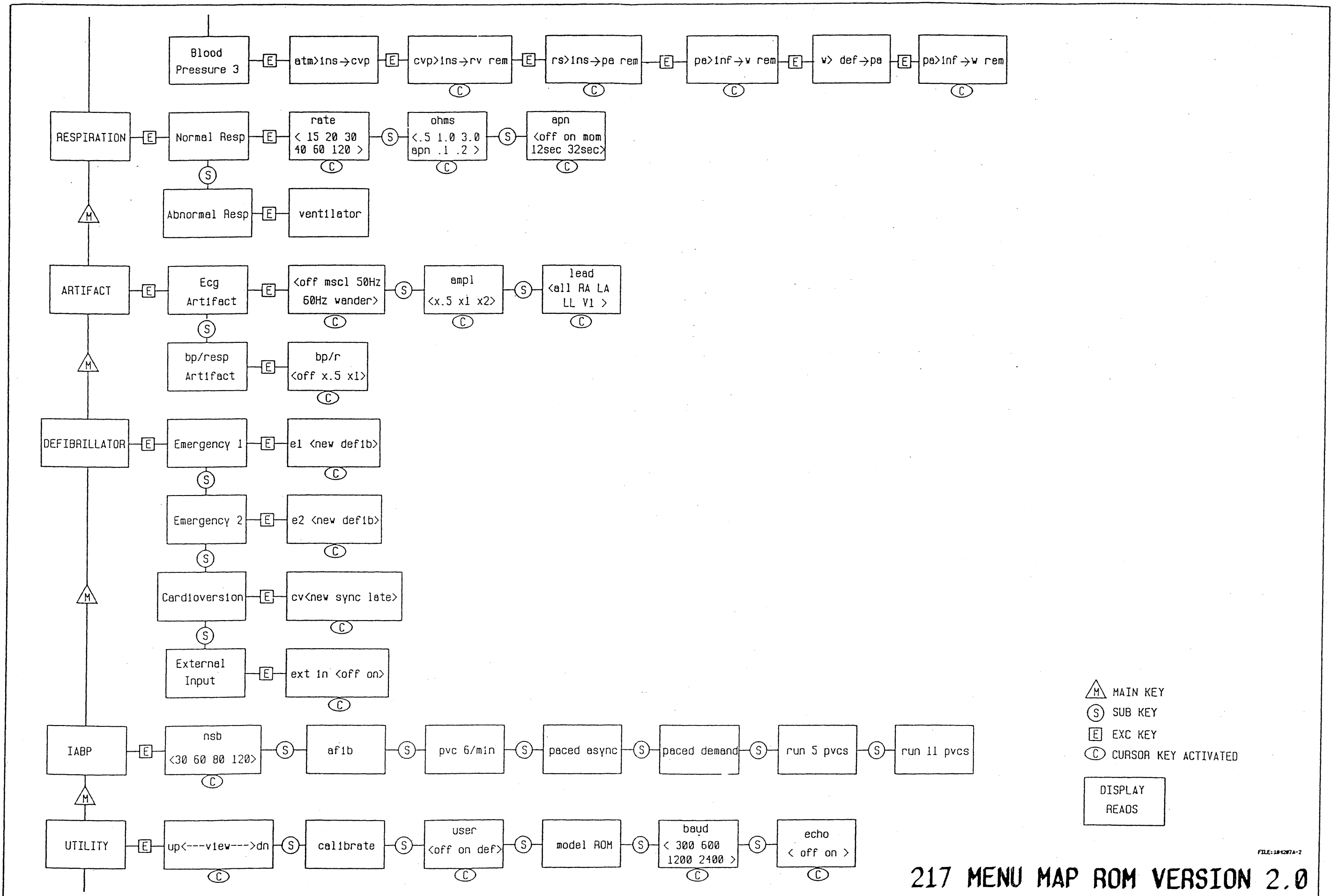

- △ MAIN KEY
- Ⓢ SUB KEY
- ⓔ EXC KEY
- ⓐ CURSOR KEY ACTIVATED

DISPLAY
READS

217 MENU MAP ROM VERSION 2.0

FILE: 18-1207A-2

| REVISIONS | | | | |
|-----------|-----|---------------------------|-------|----------|
| ZONE | LTR | DESCRIPTION | DATE | APPROVED |
| | B | INCRP ECO 278 | 10/87 | |
| | C | INCRP ECO 391 - R3 TO 100 | 10/88 | MLR |
| | D | INCRP ECO 420 - ADD D11 | 3/89 | MLR |

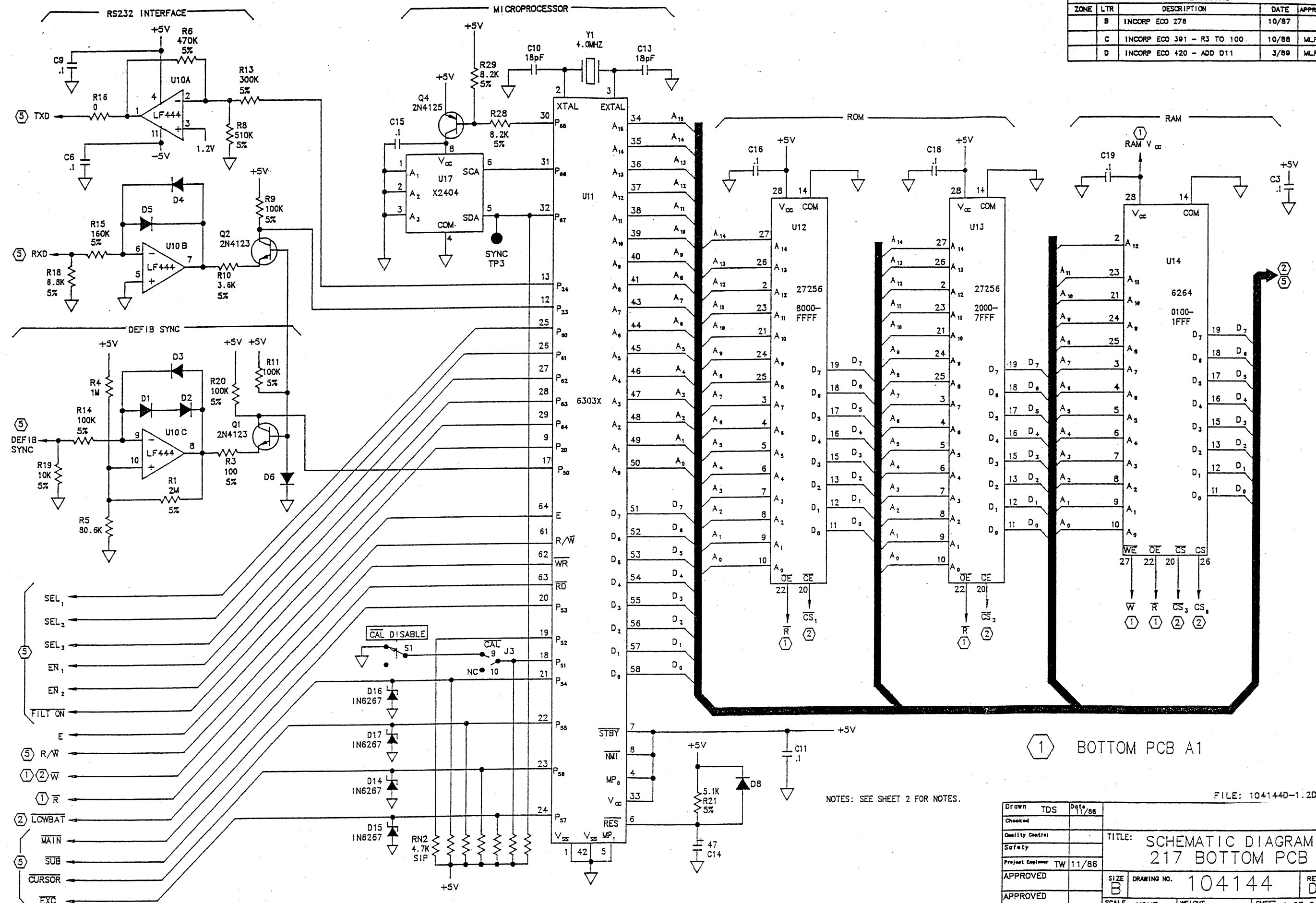

1 BOTTOM PCB A1

NOTES: SEE SHEET 2 FOR NOTES.

FILE: 104144D-1.2D

| | | | |
|------------------|-----|-------|-------|
| Drawn | TDS | Dtg | 11/86 |
| Checked | | | |
| Quality Control | | | |
| Safety | | | |
| Project Engineer | TW | 11/86 | |
| APPROVED | | | |
| APPROVED | | | |

TITLE: SCHEMATIC DIAGRAM
217 BOTTOM PCB

| | | | | | |
|-------|------|-------------|--------|--------------|---|
| SIZE | B | DRAWING NO. | 104144 | REV | D |
| SCALE | NONE | WEIGHT | - | SHEET 1 OF 2 | |

| REVISIONS | | | | |
|-----------|-----|------------------------|-------|----------|
| ZONE | LTR | DESCRIPTION | DATE | APPROVED |
| | B | INCORP ECO 278 | 10/87 | |
| | C | INCORP ECO 384 | 9/88 | MLR |
| | D | INCORP ECO 420 ADD D11 | 3/89 | MLR |

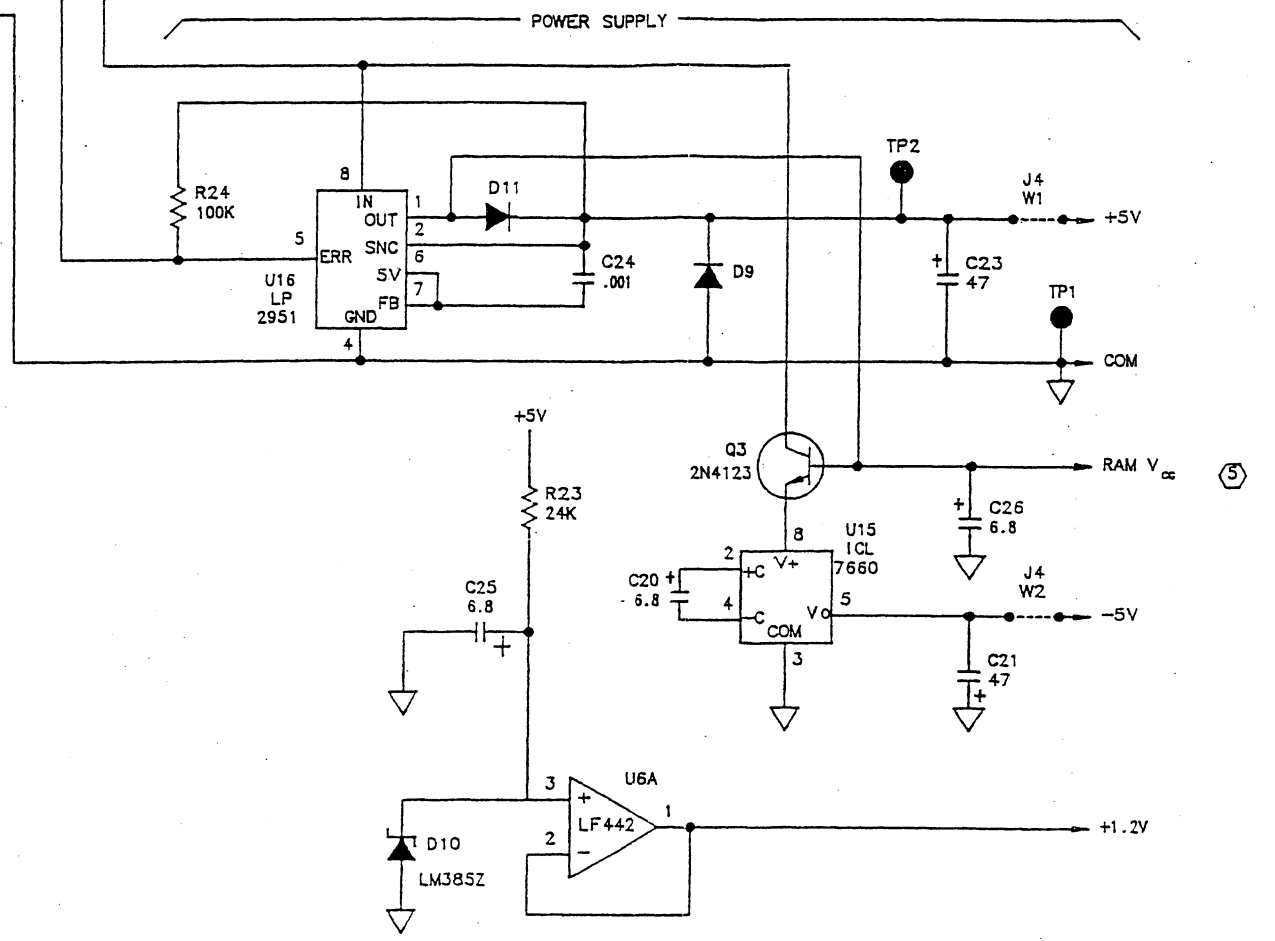
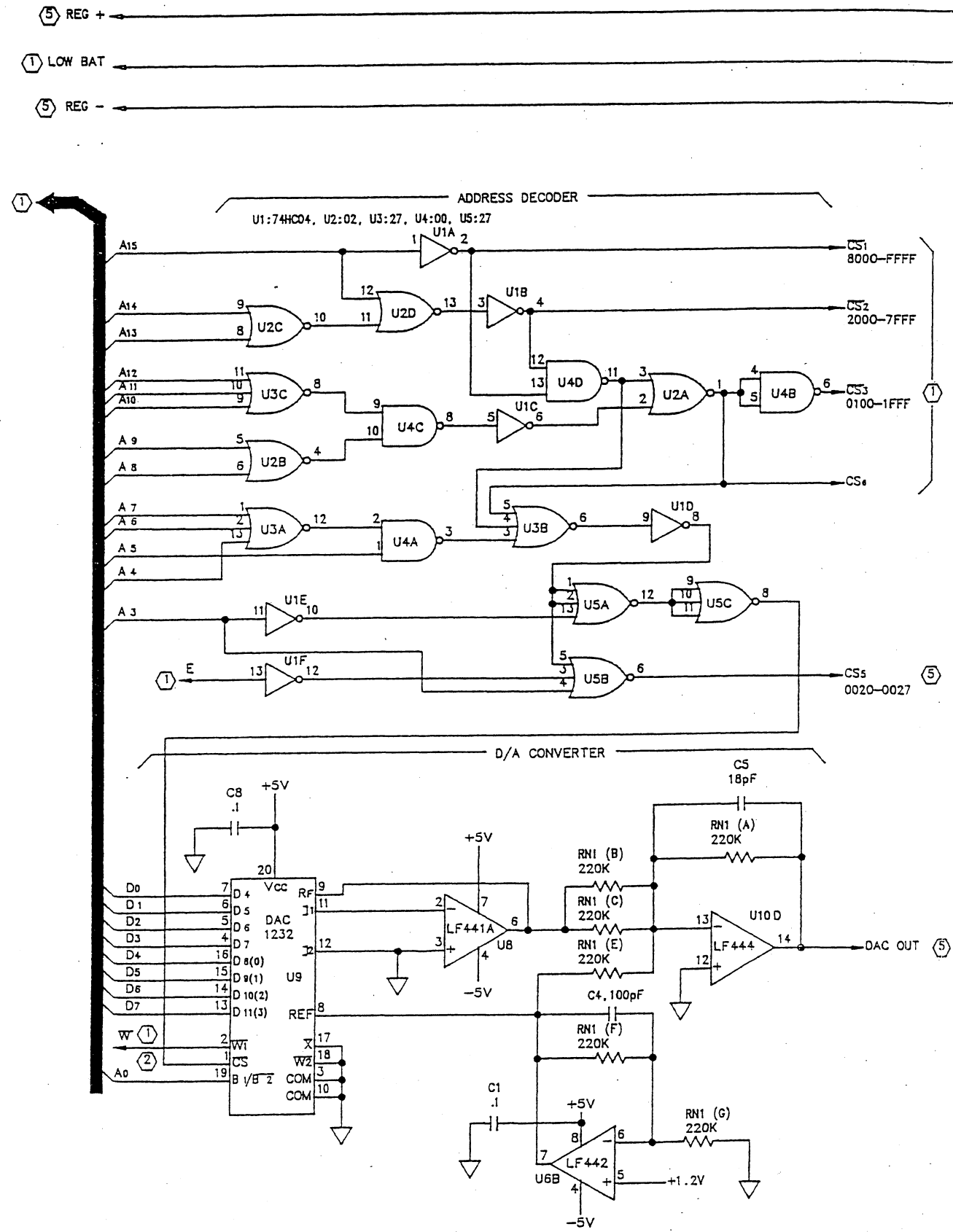

2 BOTTOM PCB A1

- NOTES: UNLESS OTHERWISE SPECIFIED
1. ALL RESISTOR VALUES ARE IN OHMS, 1%, 1/8W.
 2. ALL CAPACITOR VALUES ARE IN MICROFARADS.
 3. ALL DIODES ARE IN914.
 4. ALL 14 PIN 74HC DEVICES HAVE COM ON PIN 14.
ALL 16 PIN 74HC DEVICES HAVE COM ON PIN 8 AND +5V ON PIN 16.

FILE: 104144D2.2D

| | | | |
|------------------|-----|-------|-------|
| Drawn | TDS | Date | 11/86 |
| Checked | | | |
| Quality Control | | | |
| Safety | | | |
| Project Engineer | TW | 11/86 | |
| APPROVED | | | |
| APPROVED | | | |

| | |
|--------------------------|--------------------|
| TITLE: SCHEMATIC DIAGRAM | |
| 217 BOTTOM PCB | |
| SIZE | DRAWING NO. 104144 |
| SCALE | NONE |
| WEIGHT | - |
| SHEET | 2 OF 2 |

| REVISIONS | | | | |
|-----------|-----|-----------------|-------|----------|
| ZONE | LTR | DESCRIPTION | DATE | APPROVED |
| | B | ECO 251,256 278 | 10/87 | |

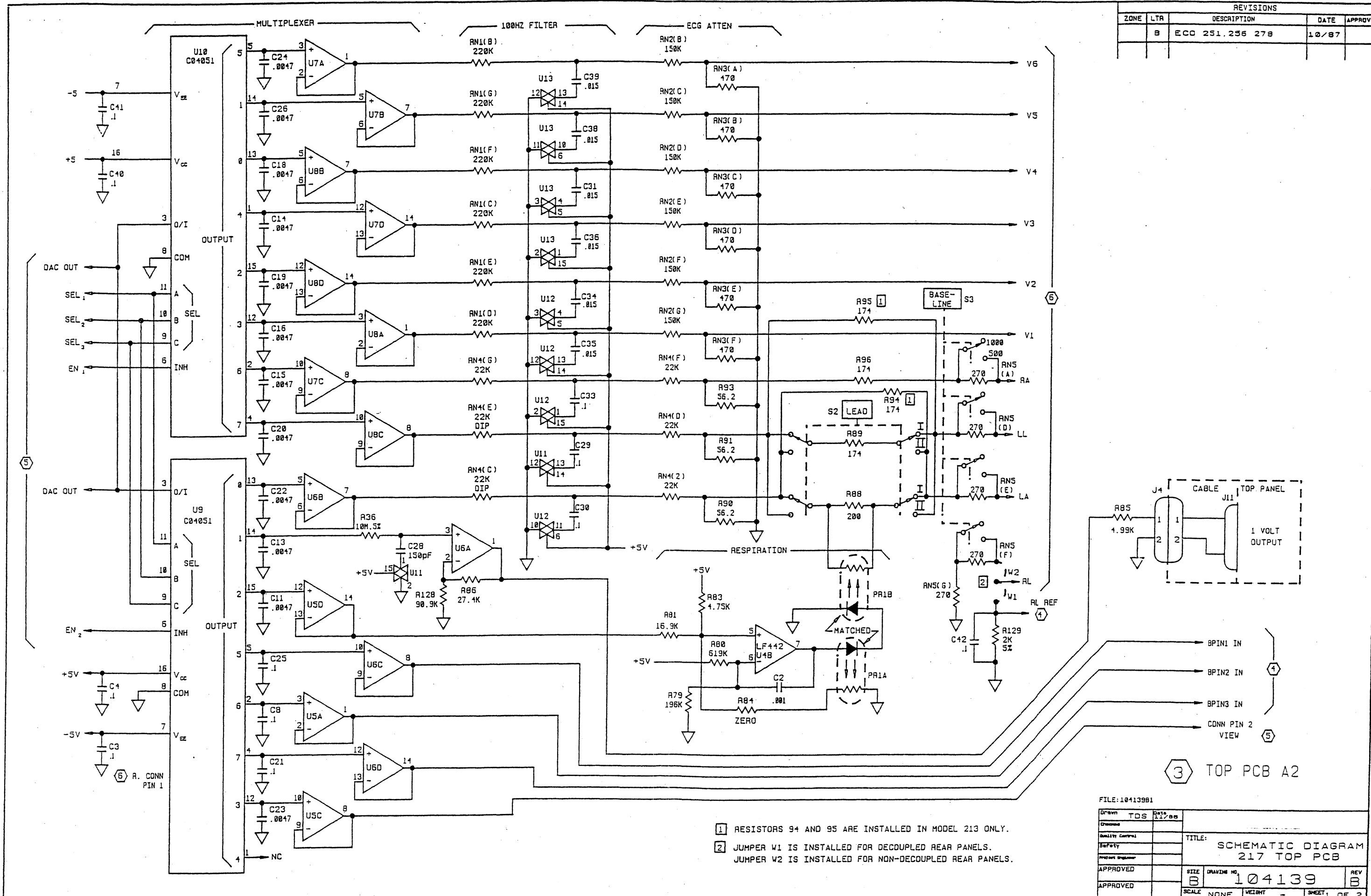

- 1 RESISTORS 94 AND 95 ARE INSTALLED IN MODEL 213 ONLY.
- 2 JUMPER W1 IS INSTALLED FOR DECOUPLED REAR PANELS. JUMPER W2 IS INSTALLED FOR NON-DECOUPLED REAR PANELS.

3 TOP PCB A2

| | | | | |
|------------------|------------|--------------------|--------------------------------------|--|
| FILE: 104139B1 | | | | |
| Drawn | TDS | Date | | |
| Checked | | | | |
| Quality Control | | | | |
| Safety | | | | |
| Product Engineer | | | | |
| APPROVED | | | TITLE: SCHEMATIC DIAGRAM 217 TOP PCB | |
| APPROVED | SIZE B | DRAWING NO. 104139 | REV B | |
| | SCALE NONE | WEIGHT - | SHEET 1 OF 2 | |

| REVISIONS | | | | |
|-----------|-----|---------------------------|------|----------|
| ZONE | LTR | DESCRIPTION | DATE | APPROVED |
| | B | INCCORP ALL ECO'S TO DATE | 9/88 | MLR |

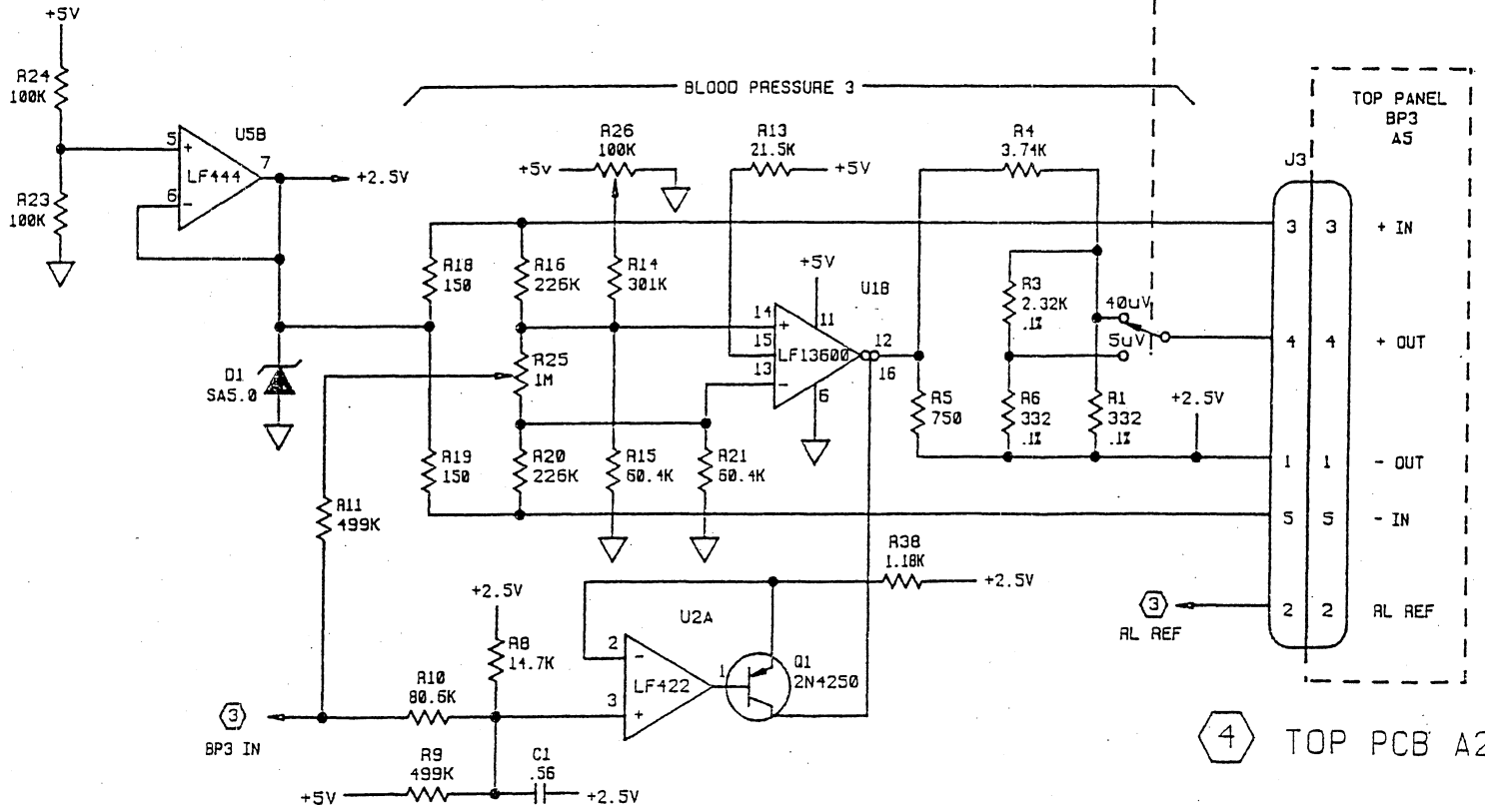
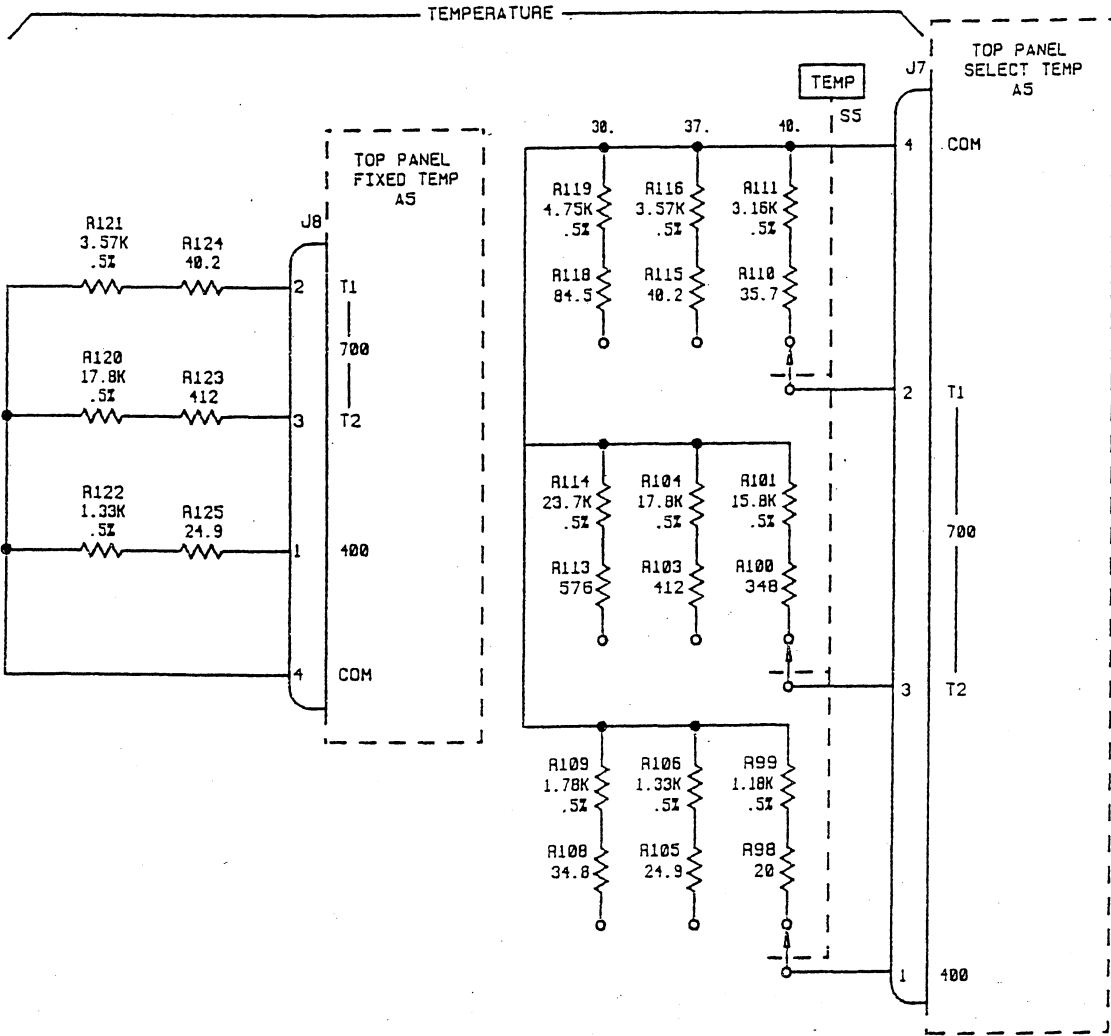
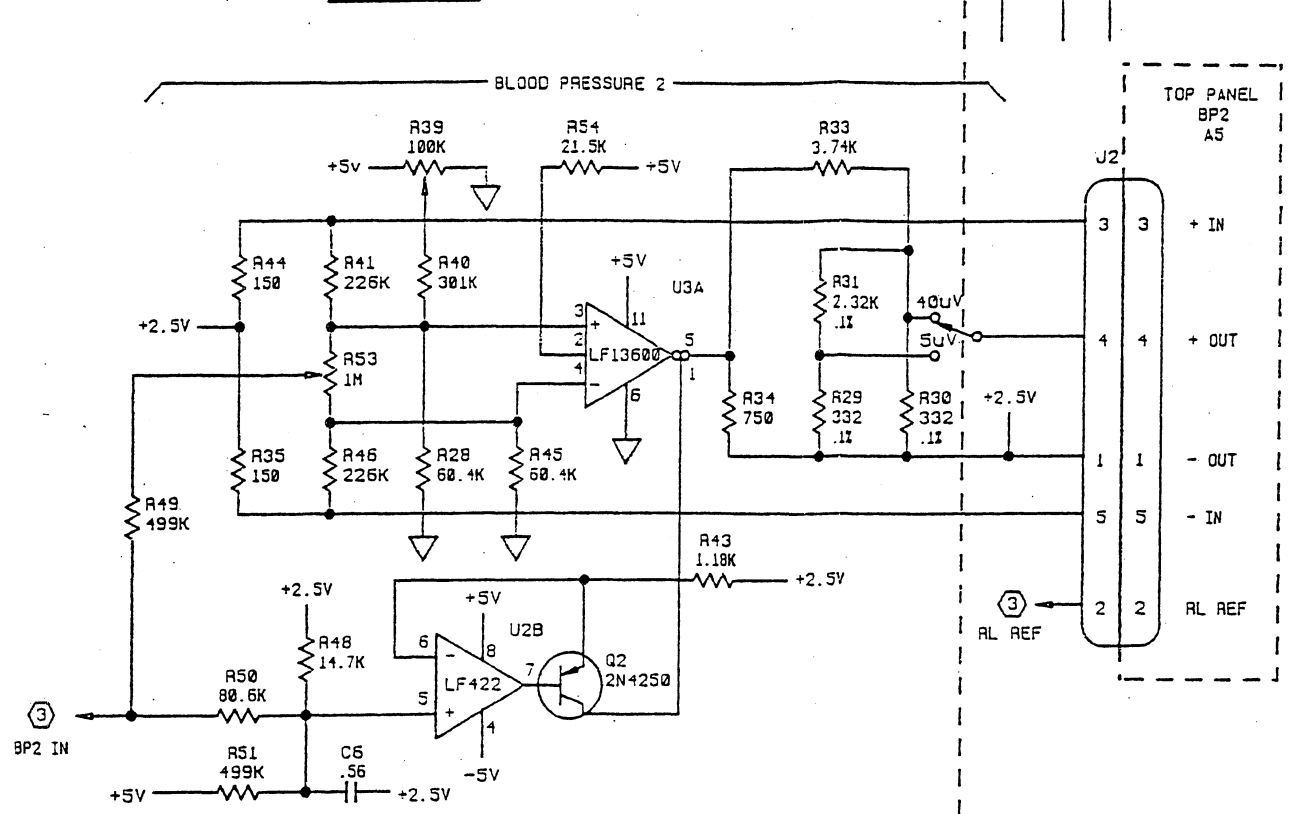
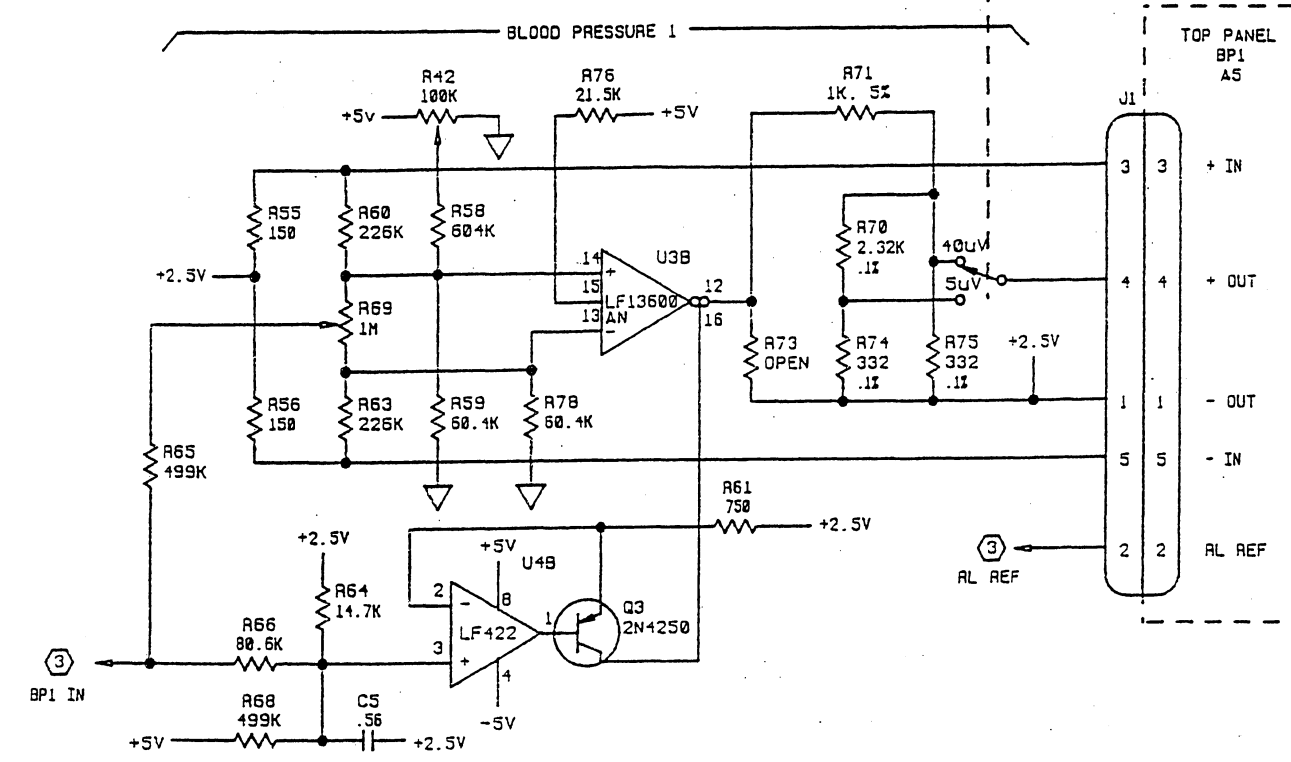

4 TOP PCB A2

FILE:104139B2

| | | | |
|------------------|--------|--------|-------------------|
| DRAWN | TDS | DATE | 13/88 |
| CHECKED | | | |
| Quality Control | | TITLE: | SCHEMATIC DIAGRAM |
| Safety | | | 217 TOP PCB |
| Project Engineer | W11/86 | SIZE | 104139 |
| APPROVED | | SCALE | NONE |
| APPROVED | | WEIGHT | - |
| | | SHEET | 2 OF 2 |

| REVISIONS | | | | |
|-----------|-----|--------------------|-------|----------|
| ZONE | LTR | DESCRIPTION | DATE | APPROVED |
| | A | PRODUCTION RELEASE | 11/86 | TV |

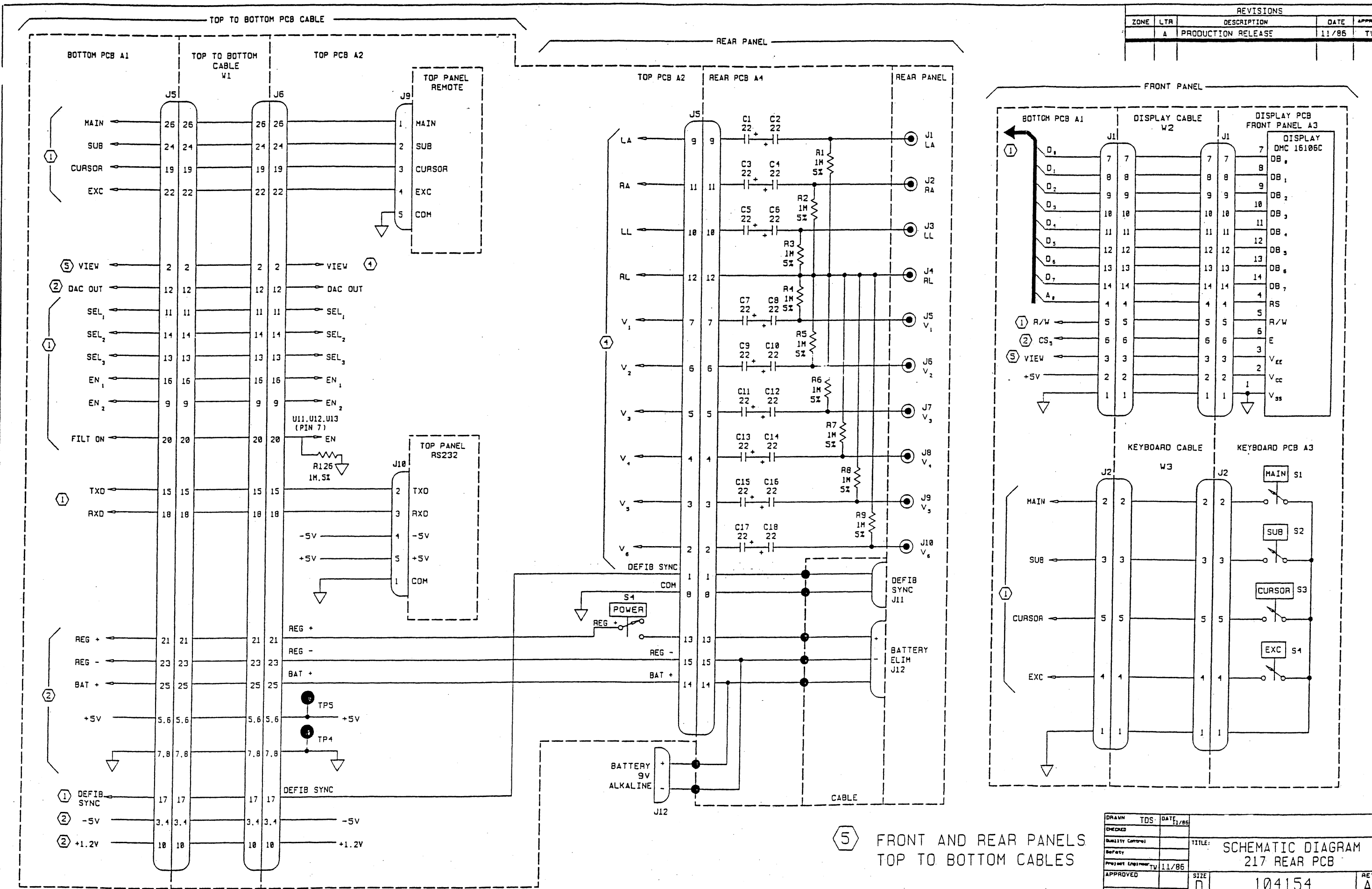

5 FRONT AND REAR PANELS
TOP TO BOTTOM CABLES

| | | | |
|------------------|------|-----------------------------------|--------------|
| DRAWN | TDS | DATE | 11/86 |
| CHECKED | | | |
| QUALITY CONTROL | | | |
| SAFETY | | | |
| PROJECT ENGINEER | TV | 11/86 | |
| APPROVED | | | |
| APPROVED | | | |
| TITLE: | | SCHEMATIC DIAGRAM 217 REAR PCB | |
| SIZE | D | 104154 | REV A |
| SCALE | NONE | WEIGHT | SHEET 1 OF 1 |

